



OAKLANDS FARM SOLAR PARK

Applicant: Oaklands Farm Solar Ltd

Environmental Statement

Appendix 4.3 – Outline Construction Environmental Management Plan
August 2024

Document Ref: EN010122/D1/6.1/Appx 4.3

Version: Deadline 1 - Clean

Planning Act 2008

Infrastructure Planning (Application: Prescribed Forms and
Procedure) Regulations 2009 - 5(2)(a)



Oaklands Farm Solar Park

Outline Construction Environmental Management Plan

Client: Baywa-re
Project/Proposal No: 5037
Version: 4.0
Date: 2024-08-06





Document Information

Project Name:	Oaklands Farm Solar Park
Document Title:	Outline Construction Environmental Management Plan
Client Name:	Baywa-re
Client Contact:	[Add contact name e.g. J. Doe]
Client Address:	[Add client address]
Document Status:	Draft
Author:	Sophia Cockell
Reviewed:	Emanuele Stella
Approved:	Emanuele Stella
Date:	2024-08-06
Version:	4.0
Project/Proposal Number:	5037
ITPEnergised Office:	4th Floor, Centrum House, 108-114 Dundas Street, Edinburgh, EH3 5DQ

Revision History

Version	Date	Authored	Reviewed	Approved	Notes
1.0	2023-11-30	S Cockell	E Stella	E Stella	First Issue
3.3	2024-01-19	H. Barnikel	E Stella	E Stella	Final Draft
3.4	2024-01-31	H. Barnikel	E Stella	E Stella	
4.0	2024-08-06	H. Barnikel	E Stella	E Stella	Update following ExA First Written Questions

© Copyright 2024 ITP Energised. The concepts and information contained in this document are the property of Energised Environments Limited, ITPE Ltd and Xero Energy Limited, trading as ITP Energised. Use or copying of this document in whole or in part without the written permission of ITP Energised companies constitutes an infringement of copyright unless otherwise expressly agreed by contract.

Limitation: This document has been prepared solely for the use of the Client and any party with whom a warranty agreement has been executed, or an assignment has been agreed. No other parties may rely on the contents of this document without written approval from ITP Energised for which a charge may be applicable. ITP Energised accepts no responsibility or liability for the consequences of use of this document for any purpose other than that for which it was commissioned, nor the use of this document by any third party with whom an agreement has not been executed.

The contents of this document are confidential to the intended recipient and may not be disclosed without their express consent. If received in error, please delete it without making or distributing copies. Opinions and information that do not relate to the official business of Energised Environments Limited registered at 4th Floor, Centrum House, 108-114 Dundas Street, Edinburgh, EH3 5DQ or ITPE Ltd., registered at 33 Colston Avenue, Bristol, BS1 4UA, or Xero Energy Limited, registered at 4th Floor, Centrum House, 108-114 Dundas Street, Edinburgh, EH3 5DQ trading as ITP Energised, are not endorsed by the company or companies.



Contents

Document Information	2
1. Outline Construction Environmental Management Plan	5
1.1 Introduction	5
1.2 Purpose	5
1.3 Content	6
1.4 Document Control	7
1.5 Responsibilities	7
1.6 Subcontractor Management	8
1.7 The Order limits	9
1.8 The Proposed Development	9
1.9 Proposed Development description	9
1.10 Compound Area	10
1.11 Programme of Works	11
1.12 Works Details	11
1.13 Main Construction Activities	11
1.14 Site Access	14
1.15 Construction and Delivery Hours	15
1.16 Artificial Lighting	15
1.17 Community Liaison	16
1.18 Monitoring	17
1.19 Operation, Loading and Unloading of Plant and Materials	17
1.20 Storage of Plant and Materials	18
1.21 Parking	19
1.22 Key Environmental Issues	19
1.23 Site Investigation	19
1.24 Criminal Activity	20
1.25 Health and Safety	20
1.26 Telecommunications and Utilities	21
2. Construction Environmental Management	22
2.1 Introduction	22
2.2 Noise and Vibration Management	22



2.3	Soil Resource	25
2.4	Outline Dust and Air Quality Management Plan	26
2.5	Site Waste Management	28
2.6	Water Quality and Pollution Management	31
2.7	Climate Change	37
2.8	Ecology Management	39
2.9	Archaeological Management	42
2.10	Public Right of Way (PRoW) Management Plan	43
3.	Environmental Management Plans	44
	References	45
	Appendix 1 Outline Soil Management plan	47
1.	Introduction	47
1.2	Roles and Responsibilities	47
1.3	Soil Resource	48
1.4	Good Practice Mitigation	49
1.5	Stop conditions	50
1.6	Preparation	51
1.7	Soil stripping	52
1.8	Creation of soil stockpiles	55
1.9	Stockpile Maintenance	57
	Appendix 2 Work Plans	58
	Appendix 3 Flood Risk Assessment and Drainage Strategy	59



1. Outline Construction Environmental Management Plan

1.1 Introduction

- 1.1.1 This outline Construction Environmental Management Plan (CEMP) refers to the construction of the Oaklands Farm Solar Park (the 'Proposed Development') which comprises a proposed solar farm with an associated Battery Energy Storage System (BESS). The Proposed Development would have a generating capacity of over 50 MW and would be situated on 191 hectares (ha) of land at Oaklands Farm to the south-east of Walton-on-Trent and to the west of Rosliston in South Derbyshire. The solar farm itself, comprising photovoltaic (PV) panel arrays, a central electricity substation and BESS together with access, landscaping and other works would be located on 135 ha of agricultural land currently in use for arable production and grazing. A high voltage underground electricity cable would then run through land at Fairfield Farm and Park Farm to the north to connect the solar farm to the national grid via an electricity substation located at the former Drakelow Power Station which sits south of Burton-upon-Trent.
- 1.1.2 As the Proposed Development would be an onshore generating station with a generating capacity of over 50 MW an application for a Development Consent Order (DCO) is being made under the Planning Act 2008 to the Planning Inspectorate, for determination by the Secretary of State for Energy Security and Net Zero.
- 1.1.3 The Proposed Development will be operated by Oakland Farm Solar Limited (hereafter referred to as 'the Applicant') and the over-arching goal is to deliver a utility-scale ground-mounted solar PV and BESS development to meet government Net Zero targets.
- 1.1.4 The Proposed Development is within South Derbyshire District Council local authority area (within Derbyshire County) and is close to the boundaries of East Staffordshire and Lichfield Districts.

1.2 Purpose

- 1.2.1 The aim of this outline CEMP is to provide a clear and consistent approach to the control of construction activities by establishing the main mitigation and control measures that will be utilised to provide robust environmental management throughout the construction period to avoid or minimise the adverse effects of the Proposed Development. A DCO would provide the necessary authorisations and consents for the Proposed Development.



- 1.2.2 The Proposed Development will be located within the 'Order limits' shown on **Figure 1.1** in this report¹.
- 1.2.3 This document does not address operational or decommissioning activities, which would be subject to separate environmental management plans and procedures (see ES Appendix 4.4: Outline Operational Environmental Management Plan and Appendix 4.5: Outline Decommissioning Environmental Management Plan).
- 1.2.4 Likely significant effects have been identified through the Environmental Impact Assessment (EIA) process and are reported in the ES. A range of 'standard' or best practice mitigation and construction management measures were accounted for in the assessments and these will be implemented during construction of the Proposed Development.
- 1.2.5 This Outline CEMP details these construction mitigation measures. It also sets out the monitoring activities designed to ensure that such mitigation measures are carried out, and that they are effective.
- 1.2.6 Where bespoke mitigation measures are proposed within the ES these are also captured within this CEMP to ensure there is one comprehensive record of all necessary construction mitigation measures.
- 1.2.7 This Outline CEMP is designed with the objective of ensuring compliance with the relevant environmental legislation and mitigation measures set out within the ES. This document provides the likely structure of the detailed CEMPs and relevant preliminary information. It indicates what additional information or controls might be included under each sub-section within the detailed CEMPs, which will be produced by the contractor(s) selected to deliver the Proposed Development's construction phase.
- 1.2.8 The Outline CEMP presents the commitments made by the Applicant to suitably limit environmental impacts of construction as part of the Proposed Development. This document will demonstrate that the Proposed Development can be delivered in such a way as to reduce, minimise or eliminate environmental impacts during the construction phase.

1.3 Content

- 1.3.1 The detailed CEMP will be prepared in accordance with this Outline CEMP, as a Requirement of the DCO and would be approved by the relevant local planning authority and consultees in advance of starting the construction works. The key elements of this Outline CEMP include:
- An overview of the Proposed Development and associated construction programme;

¹ This is Figure 1.1: Site Location in Volume 2 of the Environmental Statement



- Identification of potential environmental effects;
- Proposed design and other mitigation measures to prevent or reduce potential adverse environmental effects; and,
- Links to other complementary plans and procedures.

1.3.2 The appointed contractor(s) will be responsible for working in accordance with the environmental controls documented in the Outline CEMP and for the preparation and implementation of the detailed CEMP. Any additional construction licences, permits or approvals that are required will be listed in the detailed CEMP.

1.4 Document Control

1.4.1 The CEMP is a “live” document and will be subject to periodic review and updating. The document is intended for use by the Applicant and their contractors specifically involved in the construction of the proposed development. When this document is amended, the document control table will be updated (Table 1.1) and it will be issued to all personnel specified on the distribution list below (Table 1.2).

Table 1.1 Document Control

Status	Date Issued	Prepared by	Summary of alterations
Version 1.0	November 2023	ITPEnergised	Outline CEMP

Table 1.2 Distribution List

Organisation	Contact Name	Email	Telephone Number
Applicant – Oakland Farm Solar Limited	TBC	TBC	TBC
Principal Contractor	TBC	TBC	TBC
Ecological Clerk of Works	TBC	TBC	TBC
Archaeological Clerk of Works	TBC	TBC	TBC
South Derbyshire District Council	TBC	TBC	TBC

1.5 Responsibilities

1.5.1 It is the responsibility of all staff involved with the Proposed Development, including the Applicant, Principal Contractor and sub-contractors, to ensure the correct implementation of the CEMP and the environmental mitigation contained within.



1.5.2 During the construction phase of the Proposed Development the key environmental responsibilities are summarised below:

- The Applicant – responsible for ensuring that the Proposed Development is built in accordance with the DCO requirements and that all environmental mitigation measures stated within the Environmental Impact Assessment and this outline CEMP are implemented.
- Principal Contractor - The Principal Contractor will be engaged by the Applicant to manage and deliver the construction of Oaklands Farm Solar Park. As such they will be responsible for regularly reviewing and updating the CEMP and ensuring that all staff and sub-contractors abide by and implement the CEMP. The Principal Contractor will be responsible for the implementation of the CEMP and all the relevant environmental mitigation measures outlined in the ES.
- Ecological Clerk of Works (ECoW) - reports to the Applicant and is responsible for monitoring the implementation of the environmental mitigation measures on site prior to, during and post-construction. The ECoW will be, or will be supported by, a Suitability Qualified Ecologist (SQE).
- Archaeological Clerk of Works (ACoW) - employed to oversee the archaeological programme of works).
- All construction staff – responsible for understanding the requirements of the CEMP and the environmental sensitivities of the proposed development. All staff have an obligation to abide by the CEMP and the relevant environmental legislation for the protection of environmental receptors. Toolbox talks or other training to be provided to site staff on relevant site environmental issues to ensure precautionary working methods are adhered to.

1.6 Subcontractor Management

1.6.1 The Proposed Development will engage various subcontractors to carry out project construction related activities. These subcontractors are responsible for performing all work in conformance with relevant environmental legislation and other environmental requirements, the requirements of the CEMP, and contractual environmental requirements.

1.6.2 Subcontractors are required to develop suitable, adequate and effective method statements that explicitly define the measures to be taken to manage significant environmental risks associated with their scope of works. No works should be permitted to commence until such method statements have been developed and approved by site management. Additionally, subcontractors are required to provide sufficient and competent resources to monitor conformance with their own defined method statements.

1.6.3 The Principal Contractor will conduct monthly Site Safety and Environmental Reviews (SSERs) that will assess the environmental performance of subcontractors.



1.7 The Order limits

- 1.7.1 The Order limits are located within the administrative areas of South Derbyshire District Council, in the county of Derbyshire.
- 1.7.2 The Proposed Development comprises the construction and operation of a solar PV electricity generating facility with BESS and connection to the grid.
- 1.7.3 The area of land required for the construction, operation and maintenance, and decommissioning of the Proposed Development (the Order Limits) is shown on **Figure 1.1** of this report. This includes land required for temporary and permanent uses. The Work Plans are also included within this report at Appendix 2.

1.8 The Proposed Development

- 1.8.1 The Order limits are described in Chapter 4: Project Description of the ES and comprises the Solar Farm Site (which includes the BESS and the Substation), the Grid Connection Route and access routes.
- 1.8.2 The Site occupies a total area of approximately 191 ha. The Site lies to the south-east of Walton-on-Trent, and mainly comprises land within Oaklands Farm area (southern part of the Site) and Park Farm area (northern part of the Site) which are currently used for arable cropping and grazing (see Figure 1.3: Areas of the Site in ES Volume 2).
- 1.8.3 Land within and between the two farms (Fairfield Farm area) along with land to the north (Drakelow Power Station area) has been identified as a suitable corridor for locating the cable required to connect the Proposed Development's substation to the point of connection within Drakelow National Grid substation.
- 1.8.4 The land within Oaklands Farm slopes down to the east to a nameless tributary of the River Trent. Fields are bound by hedgerows, and some appear to have been amalgamated to create larger fields. Small copses of trees and ponds are a feature of this landscape, sometimes coinciding with former earthworks (marl pits), as are a small number of hedgerow trees. Two overhead lines (OHLs) cross both farms, running south from Drakelow Power Station.

1.9 Proposed Development description

- 1.9.1.1 The Proposed Development comprises the construction of the following buildings and infrastructure, the impact of which have been considered in this CEMP:
 - Solar PV panels;
 - Transformers;
 - Switchgear;
 - Cabling (high and low voltage);
 - Battery Energy Storage System;



- Onsite substation with control building, storage, office and welfare facilities;
- Fencing and security including CCTV;
- Drainage;
- Internal access roads and parking;
- Landscaping and habitat creation areas; and
- Construction laydown areas.

1.10 Compound Area

- 1.10.1 Temporary site infrastructure is expected to consist of, but not be limited to, single and double height portacabins, material storage, contractor parking and concrete batching plant. Temporary site infrastructure would be located on what would then become permanent infrastructure.
- 1.10.2 The principal construction will contain a number of self-contained cabins to provide offices and welfare facilities.
- 1.10.3 Power for the temporary facilities during the construction phase will be delivered by battery powered equipment where practicable. The type and exact location will be selected by the Principal Contractor and confirmed in a later revision to this document.
- 1.10.4 Water required for construction will be stored in water bowsers. Any water abstractions determined to be needed to support construction activities would be subject to the granting of appropriate licences by the Environment Agency.
- 1.10.5 No discharge of drainage shall be made to the surrounding land, and all foul water will be removed from the site by a licensed haulier.
- 1.10.6 The Principal Contractor will ensure the following:
- The footprint of the compounds is minimised where possible;
 - Adequate, clean welfare facilities will be provided for all staff;
 - All working areas will be kept in a clean and tidy condition;
 - If lighting is required, it will be designed to minimise light pollution;
 - Specific smoking areas will be provided with appropriate containers for smoking waste; and
 - All fencing, gates and/or hoarding will be inspected regularly and repaired and maintained as necessary.
- 1.10.7 As required, the Principal Contractor will fence off active working areas of the construction compounds and wider site to prevent members of the public or stray animals from entering the working areas. Any fencing or hoarding will ensure the free movement of wildlife and watercourses. All fencing and hoarding adjacent to



public roads will maintain an adequate visibility at junctions. All temporary hoarding and fencing will be removed following the completion of construction.

1.11 Programme of Works

1.11.1 An indicative construction programme is available in Appendix 4.1 Indicative Construction Programme in Volume 3 of the ES. A full detailed programme of works is to be provided in the detailed CEMP and once a contractor has been appointed.

1.12 Works Details

1.12.1 Enabling Works

1.12.2 To prepare the site for the Proposed Development, the following enabling works will be undertaken:

- Construction of site entrances.
- Establishment of construction compounds, which include site offices/welfare area and parking area.
- Upgrading, modification or improvement of highways where required for site construction.
- Preparation of land for construction, including localised site levelling (where required) and vegetation clearance.
- Import of construction materials, plant and equipment to site.
- Establishment of the construction area fence where required for construction works to progress (the installation of the perimeter fence will progress with site construction in each area and therefore will not be complete at the start of site construction).
- Construction of the internal access roads.
- Marking out the location of the operational infrastructure.
- Installation of site drainage.

1.13 Main Construction Activities

1.13.1 The main construction activities would include:

- BESS Construction
 - Installation of electric cabling.
 - Construction of foundations.
 - Import of components to site.
 - Installation of batteries, auxiliary transformer and PCS units.
 - Installation of perimeter fencing, gates and CCTV.



- Installation of water storage tanks and associated fire-fighting infrastructure
- Proposed Development Substation, compound and welfare facilities
 - Installation of electric cabling.
 - Construction of foundations.
 - Import of components to site.
 - Installation of transformers, harmonic filter, statcoms, control building, welfare building, and storage containers.
 - Installation of perimeter fencing, gates and CCTV.
 - Installation of water storage tank, deluge system and associated fire-fighting equipment.
- Trenching and installation of electric cabling
 - Cabling will in the majority be installed using open trenching methods except where required to cross watercourses, utility assets, or roads whereby directional drilling under the features may be required.
- Installation of solar panels
 - Import of components to site.
 - Piling and erection of PV module mounting structures, using mobile piling rigs to install metal piles up to 2m in depth. The panels will be installed using methods to reduce the extent of excavation and concreting required, by piling the support structures into the ground.
 - Mounting of modules to the mounting structure using hand-held power tools.
 - Trenching and installation of electric cabling.
 - Installation of string inverters and transformer units.
 - Installation of perimeter fencing, gates and CCTV.
- Micro-piling is likely to be required for most panel frame foundations due to the local ground conditions. The method of construction and requirement for piling will be confirmed once a Principal Contractor is appointed.
- Inverters, transformers and the Proposed Development's substation will not be sited within the fluvial or surface water flood risk areas.
- A stand-off distance of at least 100m is proposed between solar plant and residential properties to ensure that the Proposed Development is not dominant or overwhelming in main views. This has been increased to up to 150m for some of the properties that will experience direct views of PV panels. This stand off distance will also ensure that noise from solar plant (inverters and Medium Voltage (MV) transformers) is reduced for properties surrounding the Site. String inverters will be placed on row ends away from receptors where required. The stand off



distances also help to reduce glint and glare. The Proposed Development's substation and Battery Energy Storage System (BESS) has been moved from its previously proposed location at the PEIR1 stage near to the centre of the Oaklands Farm area, in a flatter area that is free of on-site constraints and near existing and proposed tracks. The BESS is also a potentially material noise source and moving it to the centre of the Oaklands Farm increases its distance from residential receptors to avoid adverse noise effects.

- The panels will be installed using methods to reduce the extent of excavation and concreting required, by piling the supporting structures into the ground. Use of concrete pads for panel mounting structure instead of piling into the ground is available where necessary, such as when in close proximity to an existing water pipe.
- To help integrate equipment more sympathetically into the landscape, the 2.4m high palisade fencing around the Proposed Development's substation and the BESS will be coloured a mute green or similar, and the BESS and transformers will be coloured a dark and recessive colour such as Merlin grey (RAL 180 40 05/BS 18B25) or similar. The colour will be agreed with the Local Planning Authority.
- The BESS, inverters, transformers and the Proposed Development's substation will not be sited within the fluvial or surface water flood risk areas.

1.13.2 Site Demobilisation and Reinstatement

1.13.3 Following completion of the main construction activities on site, demobilisation and reinstatement will be undertaken.

1.13.4 Specific elements of the Works will be removed including temporary construction access tracks and construction compounds and laydowns areas. These areas will be either reinstated to their use before construction began or incorporated into the proposed landscaping and ecological enhancements proposed as part of the Proposed Development.

1.13.5 The ground under the solar panels will be planted with native grassland mix and hedgerows and trees will be planted and reinstated in strategic locations to provide visual screening. An outline Landscape and Ecological Management Plan has been prepared (see Appendix 5.6: Outline Landscape and Ecological Management Plan) to set out the principles for how the land will be managed throughout the operational phase following the completion of construction.

1.13.6 Plant and Equipment

1.13.7 All plant and equipment shall be serviced and have been inspected prior to use and calibrated where applicable. As a minimum this shall consist of, but not be limited to:

- Excavators
- Ready mix concrete wagons
- Concrete pumps



- Mobile piling rigs
- Cranes
- Dumper trucks
- Low loaders
- Generators
- Fuel and water bowsers

1.14 Site Access

1.14.1 The following tracks and access points are required during the construction phase (see ES Figure 4.4: Site Access Points for location of each numbered access point):

- A new 2km Temporary Construction Haul Road will be installed across Park Farm, Fairfield Farm, and Oaklands Farm, to allow HGVs to travel from Walton Road to the construction compounds within the Oaklands Farm area. To leave the Site, HGVs will re-trace the route to exit onto Walton Road.
- Access 1B - Use of an existing (but currently unused) farm access point off Walton Road into Park Farm. This will be an entrance for HGVs and light vehicles and will not be used during operation of the Proposed Development.
- Access 1A - Use of an existing farm access point off Walton Road into Park Farm. This will be an exit only for mostly HGV construction vehicles, with a right turn only on exit. This access will not be used during operation of the Proposed Development.
- Access 2 - A new permanent access will be created north off Walton Road into land adjacent to Drakelow substation. This will be utilised for installation and ongoing maintenance of the 132kV cabling to be laid in National Grid's non-operational land adjacent to the Drakelow substation.
- Access 3 - Existing access into National Grid's Drakelow substation will be used for construction and operations works associated with connection assets within National Grid's operational compound.
- Access 4 - A new access across Rosliston Road to serve the Temporary Construction Haul Road providing access north and south only. During construction, vehicles will not be able to turn into the Site off Rosliston Road. Once construction is complete, the access on the northern side of Rosliston Road will be removed (only to be reinstated in emergency situations or at decommissioning of the Proposed Development). The access on the southern side of Rosliston Road will remain post-construction, but only as a secure gated access for response to emergency health and safety incidents.
- Access 10 - Improvements to an existing farm crossing at Coton Road. HGVs will cross Coton Road heading north and south at this crossroads but will not be able to exit onto Coton Road - all HGVs will exit the Site by travelling north along the Temporary Construction Haul Road and exiting onto Walton Road at the Park Farm Exit Junction. Smaller construction vehicles will be able to enter and exit the Site



off Coton Road if required. Abnormal Indivisible Loads (AILs) for deliveries of the large Proposed Development substation transformer units, will be able to access the Site at the Coton Road Crossroads from the east, turning right off Coton Road. The AILs will exit at the same point, turning left and following the same route back along Coton Road.

1.15 Construction and Delivery Hours

1.15.1 Core working hours are proposed to be between 07:00 until 19:00, Monday to Friday and 07:00 until 13:30 on a Saturday (unless in exceptional circumstances where need arises to protect plant, personnel or the environment).

1.15.2 To maximise productivity within the core working hours, contractors would require a period of up to one hour before and up to one hour after core working hours for start-up and closedown activities. This would include but not be limited to, movement to place of work, maintenance and general preparation works. This would not include operation of plant or machinery likely to cause a disturbance. These periods would not be considered an extension of core working hours.

1.15.3 Heavy vehicle movements would not be permitted outside of the hours referred to in Paragraph 5.2 of the OCTMP (with the exception of the hours either side of the core working hours). Furthermore, all Heavy vehicle movements will also be scheduled to occur outside of the traditional local highway network peak periods outlined below:

- AM Peak Period (08:00-09:00);
- PM Peak Period (17:00-18:00);
- School Drop off (08:30-09:30); and,
- School Pick up (15:00-16:00).

1.15.4 The Applicant will not accept Heavy vehicle deliveries to Site or let Heavy vehicles leave the Site between the traditional local highway network peak periods. This will be communicated with contractors accordingly.

1.15.5 The above restrictions do not apply to the movement of Heavy vehicles on the SRN or in relation to AILs, which will be subject to a separate agreement and licencing process.

1.16 Artificial Lighting

1.16.1 During the construction phase of the proposed development, artificial lighting may be required which could be considered a nuisance. Circumstances requiring artificial lighting may include:

- Provision of lighting at the site compound for security and safety of staff during the mornings and evenings in winter months; and
- Provision of temporary lighting along the access roads.



1.16.2 Should artificial lighting be required, the Principal Contractor will comply with the requirements of the Environmental Protection Act (UK Government, 1990). As well as implementing relevant measures set out in the Guidance Notes for the Reduction of Obtrusive Light GN01:2011 (Institute of Lighting Professions, 2011). Measures to reduce the impacts of artificial lighting include:

- Unnecessary lighting will be avoided and, following completion of the task, lighting will be switched off and/or removed. All lighting will be switched off during daylight hours;
- White light will not be used (preferable colours are 3000°k to 2700°k with peak wavelengths greater than 550nm);
- All lighting will be designed to avoid visual intrusion and/or light spillage. Lighting will be positioned and directed to avoid nuisance to residents and wildlife and/or causing distractions to drivers on adjacent roads. Lighting will also avoid spillage onto neighbouring habitats;
- If reasonably practical, lighting will be powered from mains supplies rather than from portable generators;
- Where mobile lighting relies on portable diesel generators for power, the containment of the diesel will be monitored to check for leaks and spills. Spill kits will be made available and staff provided appropriate training;
- Lighting of temporary construction compounds will be restricted to agreed working hours (one-hour period before sunrise and a one-hour period after sunset) and that which is necessary for security;
- Temporary lighting at construction compounds comprising either 4-6 light towers (up to 4 m in height) in each compound or spotlights mounted on container/welfare units, with just the entry points, walkways and front of storage facilities lit (the whole compound will not be lit up) for one-hour periods prior to the start and end of the working day; and,
- Temporary lighting overnight comprising downward facing lighting mounted on top of storage containers where materials or equipment is stored.

1.17 Community Liaison

1.17.1 Prior to construction commencing, the Applicant will actively engage with local residents to discuss the programme of work, address any concerns raised and determine how the Principal Contractor can minimise the impacts of construction on local residents.

1.17.2 The Applicant will be the first point of contact for any queries and/or grievances regarding the construction of the proposed development and will be responsible for:

- Recording all queries and/or issues raised;
- Responding in an appropriate and timely manner,



- Liaising with the planning authority in connection to any complaints; and
- Monitoring any actions that need to be implemented.

1.18 Monitoring

- 1.18.1 Environmental monitoring will be required during construction works to check compliance with set conditions and applicable environmental legislation.
- 1.18.2 A daily walkover will be undertaken by the Principal Contractor. This will cover all parts of the Site, including site compounds, site access point, monitoring points and any environmental receptors of particular sensitivity.
- 1.18.3 The Principal Contractor will review all operations to ensure compliance with the CEMP. Should deficiencies or opportunities for improvement be identified, the Principal Contractor will agree the actions required and the timescale for implementation with the staff responsible. The Principal Contractor will be responsible for recording all deficiencies, the action taken to remedy the deficiency and the success of such action. They will report to the Developer and to statutory bodies as required.

Monitoring requirements relating to noise, air quality, water, protected species, habitats, waste and traffic are specified in the respective management plans. An Environmental Monitoring Plan will be included in the final CEMP and will:

- Detail a full schedule of issues/receptors to be monitored during construction
- Provide a schedule of anticipated discharges and confirmation that permits are with either not required prohibited until such permits have been secured
- Monitor all discharges associated with construction
- Monitor any significant alteration of the physical or biological characteristics in the vicinity of the project and may be due to the project activities
- Detail corrective actions should unintended environmental effects occur
- Keep a log of monitoring activities including dates, times and remedial actions taken

1.19 Operation, Loading and Unloading of Plant and Materials

- 1.19.1 The operation of plant and machinery on site and the loading and unloading of materials, has the potential to cause nuisance for sensitive receptors. Section 2.2 outlines mitigation measures to be implemented to reduce noise impacts arising from the operation of plant and equipment during the construction of the proposed development.



1.20 Storage of Plant and Materials

1.20.1 Fuel, equipment and construction materials will be stored appropriately so as to minimise the risk of pollution and visual impact. The following measures will be implemented to prevent spillage of hazardous materials:

- Development of a Spill Response Plan and provision and maintenance of spill response equipment;
- Storage of hazardous materials no less than 20 meters away from a watercourses/drainage gullies and outside of the River Mease Special Area of Conservation (SAC) catchment;
- Completion of a Control of Substances Hazardous to Health (COSHH) assessment for hazardous materials;
- Development of a COSHH Register documenting materials stored and handling requirements;
- Segregation of COSHH raw material stores and COSHH waste stores;
- Storage of hazardous material containers on secondary containment systems that will contain 110% of the contents of the largest container or 25% of the total, whichever is greater;
- Protection of hazardous materials in locked containers to minimise the ingress of rainwater and secure them against accidental damage;
- Refuelling and maintenance to be undertaken within the site compound away from all watercourses within or adjacent to the Site and outside the River Mease SAC catchment;
- Fixed plant to be self-bunded, mobile plant to be kept clean and in good working order, and fitted with drip trays, where appropriate;
- Spillage kits and oil absorbent material to be carried by mobile plant and located at vulnerable locations (e.g. crossings of land drains/ditches);
- Train staff in the use of spill kits and the correct disposal of used material;
- Maintain a log of any incidents;
- All construction plant and machinery will be inspected on a daily basis to check for fuel and oil leaks and, where necessary, drip trays or plant nappies will be used to collect leaks;
- Secure Site to prevent vandalism events which could lead to pollution; and
- Materials and machinery will be stored tidily during the works. Machinery will not be left in place for longer than required for construction purposes, in order to minimise its impact on views.



1.21 Parking

1.21.1 Parking for construction workers, deliveries and site visitors will be accommodated within the proposed development site and would not impact on the public road network.

1.22 Key Environmental Issues

1.22.1 Potential environmental effects relating to each activity are provided in each Chapter of Volume 1: Environmental Statement.

1.23 Site Investigation

- In order to inform the design of the Proposed Development, a programme of intrusive targeted site investigation will be required. This is a pre-commencement requirement in the draft DCO. During this process, the site investigation will target potential areas of made ground infill to former pits, reservoirs/ponds and in the area of former buildings at New Barn. Soil sampling, laboratory analysis and a suitable assessment shall then be undertaken in accordance with current best practice in order to ascertain the potential risk posed to ground conditions human health and the wider environment.
- If this assessment determines that remediation or risk management is required in order to address any potential risks posed by made ground, a process of remediation options appraisal, remediation strategy, remediation implementation and verification shall be entered into. This work is standard practice and standard effective mitigation exists, improving the ground conditions such that any risks posed are reduced to acceptable levels.
- The Applicant is committed to undertaking any remediation of soils or groundwater that is deemed required following the investigation and assessment of ground conditions as set out in the pre-commencement requirement of the draft DCO.
- If contaminated land is encountered on Site (C5 – Table 9.7 of the ES), the Applicant will adhere to LCRM best practice implementing a programme of targeted site investigation, assessment and remediation and/ or risk management shall be implemented in the construction phase. Soil sampling, laboratory analysis and contaminated land assessment shall then be undertaken in accordance with LCRM and current best practice to ascertain the potential risk posed to ground conditions human health and wider environment.



1.24 Criminal Activity

- 1.24.1 Instances of theft of copper wiring and other materials and equipment have been reported at solar farms globally. Unauthorised access has the potential to result in fire if persons are intent on damage/sabotage. To prevent unauthorised access, during all stages of the Proposed Development the Site will be suitably secure to protect from criminal damage. This includes secure fencing and gated entrances, CCTV and remote monitoring, and lighting of critical areas (secured within the CEMP, OEMP and DEMP). On site staff during all phases will also act as a deterrent to criminal activity.
- 1.24.2 Deer fencing is designed to integrate into the agricultural landscape character (wooden poles with steel wire mesh and potentially a single line of barbed wire). Where additional security is required along Coton Road, wire mesh fencing with steel posts will be installed.

1.25 Health and Safety

- 1.25.1 The Proposed Development, including all construction and operation activities, will comply with all relevant UK legislation including: the Health and Safety at Work etc. Act 1974; the Construction (Design & Management) Regulations 2015; the Management of Health & Safety at Work Regulations 1999; and the Waste Batteries and Accumulators Regulations 2009.
- 1.25.2 The CEMP, OEMP and DEMP all contain measures to ensure the health and safety of workers. All staff and contractors working on the construction of the Proposed Development will be required to comply with the safety procedures set out in these management plans.
- 1.25.3 To ensure hazards are appropriately managed, a risk assessment will be undertaken for all major construction activities, with measures put in place to manage any hazards identified. For example, appropriate on-site management of construction vehicles to avoid accidents or injury.
- 1.25.4 Security fencing will be erected around the Proposed Development boundary during construction. In addition, more robust palisade fencing will be erected around the Proposed Development's substation compound and BESS, and CCTV will be installed on metal masts up to 3.5m in height for additional safety and security.
- 1.25.5 Existing electricity transmission and distribution lines which pass through the Site present a risk including the potential for construction vehicles (cranes etc.) to collide with the power lines and pylons collapsing on the solar PV panels. Exclusion zones agreed in consultation with network operators either side of overhead and underground lines have been maintained to allow access to the pylons by network maintenance teams, while providing suitable construction access for the safe use of tall solar construction equipment.



1.25.6 The presence of the underground 132kV cable connecting the Proposed Development's substation with the National Grid Drakelow substation could also pose a risk if landowners decide to carry out intrusive works in the future. This will be mitigated with the use of typical safety measures for underground utility installations such as burying assets below plough depth (typically 900mm below surface), signposting of the cable route on the surface with poles/markers, underground markers such as tiles and safety tape placed above cabling to alert workers during excavations, and information provided to the landowner highlighting the risk of impacting the underground cable which can be shared with future landowners. Land agreements will include plans showing the approximate routing of the installed cabling, and title updated to reflect the easement(s) to ensure any parties who may acquire the land in the future will be aware of the asset's location.

1.25.7 Development of and adherence to a Safe System of Work under the Health and Safety at Work Act 1974 and CDM (2015).

1.26 Telecommunications and Utilities

1.26.1 The Applicant has consulted with utilities operators to identify necessary easement corridors required for the overhead lines and other utility assets that cross the Site. Where necessary construction methods have been discussed where construction activities (e.g. cabling) need to cross assets.

1.26.2 In addition, consultation with regards to Protective Provisions has also taken place and where any existing utility assets are likely to be impacted Protective Provisions will be sought to be agreed with that provider. Thereafter any works within an agreed distance of the asset will require to be undertaken in accordance with the requirements set out in the Protective Provisions. As measures are in place to ensure the protection of all utility assets it can be concluded that no adverse effects on utilities are expected.

1.26.3 Ground penetrating radar and other suitable techniques will be used before excavation to identify any unknown utilities, and this will be followed by consultation and agreement of construction / mobilisation methods prior to works commencing.

1.26.4 Pre-construction checks for utilities and other infrastructure will be undertaken.



2. Construction Environmental Management

2.1 Introduction

- 2.1.1 This section of the Outline CEMP sets out the mitigation and management measures to be included as a minimum in the detailed CEMP. It also identifies where monitoring is proposed to assess the effectiveness of the mitigation measures.
- 2.1.2 Best practice construction methods will be implemented in relation to noise and vibrations; soil resources; dust and air quality; waste management; water quality and pollution; habitats (including invasive species, ancient woodland); biosecurity; and species (including bats, badger, reptiles, otter, skylark).

2.2 Noise and Vibration Management

2.2.1 Working hours

- 2.2.1.1 The following operations may, where necessary, continue or take place on an exceptional basis outside the working hours above - construction techniques which cannot be interrupted safely; or works required to mitigate delays to construction due to extreme weather conditions.
- 2.2.1.2 If any activity is considered necessary outside of these hours, the contractor should liaise with the Local Authority and nearby affected stakeholders. The contractor may wish to apply for a Section 61 of the Control of Pollution Act to the Local Authority for these specific works.
- 2.2.1.3 No working is proposed at night, with the possible exception of directional drilling for cable laying below Rosliston Road for a short period. If a contractor determines a need to undertake work at night, the Contractor will discuss the proposed works with the LPA with respect to timings, working methods, allowable noise limits, liaison with residents, noise and vibration monitoring, and s61 applications, prior to the works taking place.

2.2.2 Noise and Vibration action levels

- 2.2.2.1 During construction, the principles presented with BS 522811 Section 7.3 Execution of works will be followed: *“All available techniques should be used to minimise, as far as is appropriate, the level of noise to which operators and others in the neighbourhood of site operations will be exposed”*. These include consideration to the hours of working, quiet working methods where reasonably practicable, control of the construction noise at source, and control of the spread of noise (section 8 of BS 5228).



- 2.2.2.2 For reference, baseline noise levels were measured in 2021 and reported in Appendix 11.1 of the ES. The contractor should liaise with the Local Authority as to whether an update baseline noise survey is required before the start of works, where ambient noise levels are considered to have changed significantly.
- 2.2.2.3 Guideline criteria for evaluating the magnitude of construction noise and setting limits are provided in the informative guidance at Annex E of BS5228-1:2009+A1:2014; At section E3 a lower limit of 65 dB LAeq, 12 hour during the daytime is indicated based on the relatively low existing ambient noise in the vicinity.
- 2.2.2.4 Where levels are predicted to exceed 65 dB LAeq, 12 hour the contractor should liaise with the affected residence, to inform them of the proposed working methods, duration, timings and steps being taken to minimise potential disruption or duration of potential disruption. The contractor may wish to apply to the Local Authority for a section 61. This could include provision for noise and/or vibration monitoring as part of an agreement, where appropriate.
- 2.2.2.5 Contractors should aim to ensure that a Peak Particle Velocity is below 1mm/sec, as set out in Table B.1 of and BS5228-2:2009, as the level at which complaints are likely but can be tolerated if prior warning and explanation has been given.
- 2.2.2.6 Whilst not anticipated, if this is not possible to achieve for short periods of exceptional works, a Peak Particle Velocity of 10mm/sec should not be exceeded, and prior warning must be given to occupiers of affected residential properties.

2.2.3 Noise and vibration controls

- 2.2.3.1 The Contractor will be required to undertake Best Practical Means (BPM) as defined in s79(9) of the EPA and s72 of the Control of Pollution Act 1974 (CoPA).
- 2.2.3.2 Best Practical Means as described in the Control of Pollution Act 1974 will be adopted including: Selection of low noise plant and construction techniques where possible; application of noise silencers; application of rubber linings in dumpers to reduce noise impact; minimise drop height of materials; all plant to be properly maintained and operated in accordance with manufacturer's instructions. Any fixed construction plant items to be located as far from noise sensitive properties as possible and screened if required and practical with temporary hoardings. Control of working hours and liaison with the Local Authority and nearby affected stakeholders where planned works outside of these hours is considered necessary.
- 2.2.3.3 The Contractor will have a duty to follow the recommendations set out in BS 5228:2009. In particular the Contractor will ensure:
- Only plant conforming with relevant national or international standards, directives or recommendations on noise or vibrations emissions will be used.
 - All vehicles fitted with effective exhaust silencers which are in good working order.



- Avoiding loud audible vehicle reversing sirens and not setting the volume higher than is necessary to be compatible with safety requirements.
- All construction machines and plant should be switched off or their noise output significantly reduced when not in use, and must not be left idling unnecessarily.
- All plant shall be maintained in good working order, following the manufacturers recommendations, so as to minimise unnecessary noise (such as squeaks, creaking or rattling).
- Noisy plant (for example generators) will be located as far away as practicable from residential properties. Where fixed sources of noise need to be located closer to noise sensitive receptors, quiet plant should be selected and barriers such as soil mounds, acoustic sheds or other noise screening should be used where practical.
- Loading and unloading activities are undertaken in a considerate manor away from residential properties as far as practicable, to reduce impact noise. Minimise drop height of materials.
- Haul routes, access points and traffic management are strictly followed.
- Where reasonably possible, plant will be selected to provide oversizing and redundancy to ensure equipment is operating below maximum capacity (highest noise levels typically occur when plant is operating at maximum capacity).
- As part of the detailed design stage, the Applicant will be required to undertake and submit an operational noise assessment to the local planning authority prior to the start of works on site (DCO requirement 15) to demonstrate that detailed design and plant selected do not demonstrably affect noise sensitive receptors in accordance with the conclusions of this assessment.



- 2.2.3.4 In addition, Best Practical Means as described in the Control of Pollution Act 1974 will be adopted including: Selection of low noise plant and construction techniques where possible; application of noise silencers; application of rubber linings in dumpers to reduce noise impact; minimise drop height of materials; all plant to be properly maintained and operated in accordance with manufacturer's instructions; and any fixed construction plant items to be located as far from noise sensitive properties as possible and screened if required and practical with temporary hoardings.
- 2.2.3.5 Where potentially noisy works are proposed near to residential properties, the Contractor will liaise with the nearby residential properties to keep them informed of when noisy works may occur and for how long and provide appropriate contact information.
- 2.2.3.6 To minimise noise during construction, there is an aim to “do minimum” to the Site. This means soil stripping, trench building and drainage ditches are minimised. Concreting operations are restricted to the transformer / the Proposed Development's substation / BESS compounds, and if required pad foundations for solar panels over the water main through the south of the Site.
- 2.2.3.7 Noise was considered during the Site design process in the placement of solar plant (inverters and Medium Voltage (MV) transformers). A stand-off distance of at least 100 m is currently proposed between solar plant and residential properties.
- 2.2.3.8 The proposed location of equipment is set out within the Work Plans (See ES Appendix 1.3: Work Plans) however the exact location and specification of operational equipment will be determined when finalising the design specification. The design specification of any operational plant will consider noise emissions in their selection; the quietest plant will be selected where other non-acoustic design considerations allow (subject to available acoustic data).
- 2.2.3.9 The Contractor will have a duty to follow the best practice recommendations set out in BS 522811. Training of site personnel to raise awareness of noise, the location of noise sensitive receptors nearby, and delivery/access routes will be provided. The Contractor would also be required to make appropriate checks, keep records that the procedures within the CEMP are being followed, and have a clear complaints procedure.

2.3 Soil Resource

- 2.3.1 An Outline Soil Management Plan (OSMP) is available in Appendix A to sets out principles and procedures for good practice (embedded mitigation measures) and bespoke mitigation measures in soil handling, storage and reinstatement to be used for the Proposed Development. The outline plan describes the principles that



the Principal Contractor will follow to minimise adverse effects on the nature and quality of the soil.

2.4 Outline Dust and Air Quality Management Plan

2.4.1 Outlined below are recommendations for mitigation measures to be implemented during construction to control dust and air quality impacts. These mitigation measures are proportionate to the level of risk assessed using the methodology set out in Institute of Air Quality Management Guidance on the assessment of dust from demolition and construction (Institute of Air Quality Management, 2019).

2.4.2 Proposed mitigation for communications:

- Display the name and contact details of person(s) accountable for environmental issues on the site boundary; and
- Display the head or regional office contact information.

2.4.3 Proposed mitigation for dust management:

- Develop and implement a Dust Management Plan (DMP). This may include measures to control other emissions, approved by the Local Authority.
- Plan the site layout so that machinery and dust-causing activities are located away from receptors, as far as is possible.

2.4.4 Proposed mitigation for site management:

- Record all dust and air quality complaints, identify cause(s), take appropriate measures to reduce emissions in a timely manner, and record the measures taken;
- Make the complaints log available to the local authority when asked; and
- Record any exceptional incidents that cause dust and/or air emissions, either on- or off-site, and the action taken to resolve the situation in the logbook.

2.4.5 Proposed mitigation for monitoring:

- Carry out regular site inspections to monitor compliance with the DMP, record inspection results, and make an inspection log available to the Local Authority when asked;
- Increase frequency of site inspections by the person accountable for air quality and dust issues on site when activities with a high potential to produce dust are being carried out and during prolonged dry or windy conditions; and
- Agree dust deposition, dust flux, or real-time PM10 continuous monitoring locations with the Local Authority. Where possible commence baseline monitoring at least three months before work commences.

2.4.6 Proposed mitigation for preparing and maintaining the site:

- Plan site layout so that machinery and dust causing activities are located away from receptors, as far as possible;



- Erect solid screens or barriers around dusty activities or the site boundary that are at least as high as any stockpiles on site;
- Fully enclose site or specific operations where there is a high potential for dust production and the site is active for an extensive period;
- Keep site fencing, barriers and scaffolding clean using wet methods;
- Remove materials that have a potential to produce dust from site as soon as possible, unless being re-used on site; and
- Cover, seed or fence stockpiles to prevent wind whipping.

2.4.7 Proposed mitigation for site operations:

- Prevention or reduction of dust through timing of works or damping down;
- Only use cutting, grinding or sawing equipment fitted or in conjunction with suitable dust suppression techniques such as water sprays or local extraction, e.g. suitable local exhaust ventilation systems;
- Ensure an adequate water supply on the site for effective dust/particulate matter suppression/mitigation, using non-potable water where possible and appropriate;
- Minimise drop heights from loading or handling equipment and use fine water sprays on such equipment wherever appropriate; and
- Ensure equipment is readily available on site to clean any dry spillages and clean up spillages as soon as reasonably practicable after the event, using wet cleaning methods.

2.4.8 Proposed mitigation for waste management:

- Prohibit all fires on site, including for the burning of waste materials.
- Use enclosed chutes, conveyors and covered skips.

2.4.9 Operating vehicle/machinery and sustainable travel:

- Ensure all vehicles switch off engines when stationary;
- Limit the use of diesel- or petrol-powered generators and use mains electricity or battery powered equipment where practicable;
- Impose and signpost a maximum speed limit of 15 miles per hour (mph) on surfaced and 10 mph on unsurfaced haul roads and work areas (within the vicinity of sensitive habitats, vehicles will be restricted to 5mph (e.g., active badger sett, otter holts); and
- Issue all suppliers and contractors with delivery routes and access times/restrictions.

2.4.10 Proposed mitigation specific to earthworks:

- Re-vegetate earthworks and exposed areas/soils stockpiles to stabilise surfaces as soon as practicable;



- Use Hessian, mulches or trackifiers where it is not possible to re-vegetate or cover with topsoil, as soon as practicable; and
- Only remove the cover in small areas during work and not all at once.

2.4.11 Proposed mitigation specific to construction:

- Avoid scabbling (roughening of concrete surfaces) if possible;
- Ensure sand and other aggregates are stored in bunded areas and are not allowed to dry out, unless this is required for a particular process, in which case ensure that appropriate control measures are in place;
- Ensure bulk cement and other fine powder materials are delivered in enclosed tankers and stored in silos with suitable emission control systems to prevent escape of material and overfilling during delivery; and
- For smaller supplies of fine powder materials ensure bags are sealed after use and stored appropriately to prevent dust.

2.4.12 Proposed mitigation specific to track-out:

- Use water-assisted dust sweeper(s) on the access and local roads, to remove, as necessary, any material tracked out of the site. this may require a sweeper being continuously in use;
- Avoid dry sweeping of large areas;
- Ensure vehicles entering and leaving sites are covered to prevent escape of materials during transport;
- Inspect on-site haul routes for integrity and instigate necessary repairs to the surface as soon as reasonably practicable;
- Mud to be controlled at entrance/exit to the Site using wheel washes and/or road sweepers; and
- Record all inspections of haul routes and any subsequent action in a site logbook.

2.5 Site Waste Management

2.5.1 Introduction

2.5.1.1 The Site Waste Management Plan (SWMP) for the Proposed Development will be prepared and appended to the detailed CEMP to outline the practices to be put in place to ensure the control of waste on site, in a manner that is not detrimental to the local and wider environment. This encompasses the minimisation of waste and the removal of waste from site where necessary.

2.5.1.2 The Principal Contractor will consider the objectives of sustainable resource and waste management and seek to use material resources efficiently, reduce waste at source, reduce waste that requires final disposal to landfill and apply the principles of the waste hierarchy.



2.5.1.3 The types, quantities and final destination of waste generated during the construction phase would be identified, measured and recorded through the SWMP. The SWMP will:

- Identify personnel with waste management responsibilities;
- Describe the proposed works;
- Outline opportunities for waste minimisation/reuse in line with the requirements of the waste hierarchy;
- Review any outline decisions taken to minimise the amount of waste produced on site;
- Provide a forecast of waste types and estimated arisings and outline how they will be managed.

2.5.1.4 The following benefits will result from the implementation of the Site Waste Management Plan:

- A reduction in waste being sent to landfill;
- a reduction in material purchase, disposal and landfill costs;
- avoidance of nuisance arising from dust and odour;
- a reduction in vehicle movements on site and in the local area; and
- reduction of impact on local communities.

2.5.1.5 It is anticipated that the construction of the Proposed Development will give rise to the following types of waste:

- wood;
- domestic (e.g. glass, paper, cardboard, plastics, food, sewage); and,
- metal (e.g. wire, steel).

2.5.2 Strategy for Waste Reduction

2.5.2.1 The Principal Contractor will employ the following strategy to achieve maximum reuse and reduce landfill waste:

- Sub-contractors will be contractually obliged to cooperate with the Site Waste Management Plan as part of their tender;
- All staff will be encouraged to engage in site inductions and environmental awareness campaigns;
- Waste management will be incorporated into the design process, including planning for high volumes of waste, consideration of suitable manufacturers and appropriate storage measures;
- The Principal Contractor will identify and segregate waste streams;
- The Principal Contractor will reuse and recycle where possible;
- The Principal Contractor will use suitable storage methods for all materials; and



- Unauthorised waste disposal will be treated as an environmental incident and the Pollution Incidence Response will be implemented. Under no circumstances will waste material be burned or buried on the Proposed Development site.

2.5.3 Development Waste Management Specifics

2.5.3.1 The following measures will be implemented to minimise the environmental impacts of construction waste arising from the proposed development.

Elimination:

- The Proposed Development will aim to avoid the creation of waste through the detailed design stages. The control of design will reduce the risk of late stage changes which would require rework and therefore reduce overall waste.

Reduction:

- The Principal Contractor will undertake accurate measurement and ordering of required materials to reduce the volume of waste generated during construction (e.g. ordering standardised sizes to reduce onsite cutting);
- Order materials on a just-in-time basis to reduce onsite storage time;
- The Principal Contractor will ensure the effective and appropriate storage of materials to protect against damage and adverse weather conditions;
- Ensure suppliers have a take-back option for packaging and surplus;
- Maintain good communication with suppliers to reduce the amount of packaging included in deliveries;
- The Principal Contractor will ensure the use of enclosed containers to store waste susceptible to spreading by wind or liable to cause litter; and
- Remove general waste at frequent intervals and keep the site kept clean and tidy.

Waste Storage, handling and segregation:

- Store wastes in areas away from surface or foul drains and watercourses;
- Segregate all construction wastes, at a minimum, into hazardous and non-hazardous waste streams;
- Segregate construction wastes into dry recyclables;
- Cover waste containers if there is a risk that wastes may be blown out or the wastes contained therein are water sensitive (e.g. plasterboard wastes);
- Store waste oils in 110% bunding;
- Use waste signage such as labels that specify waste contents; and
- Secure waste containers. Skips should be lockable if the site is insecure or vulnerable to theft and vandalism.

Re-Use:

- Uncontaminated excavated material arising during construction; and,



- Subsoil in landscaping areas and restoration post construction.

Recycling:

- The Principal Contractor will designate areas or containers for materials which can be recycled such as plastics, timber, steel, general waste, dry recyclables, batteries, etc.

Off-site Disposal of Site Waste Streams:

- Use the GT Non-Hazardous Waste Transfer Note (WTN) for the off-site disposal of all non-hazardous wastes;
- Only use licensed waste carriers to transport wastes from site and obtain documentation to demonstrate registration;
- Obtain full copies of the Waste Management Licences or Exemptions for the disposal locations of site waste streams;
- Periodically follow a waste vehicle to its destination where: the condition of the waste contractor's vehicle is poor, the waste contractor's waste paperwork is weak, a waste contractor uses a lower tier waste haulage company, higher risk waste is being transported e.g. oily wastes, or there is a suspicion wastes are being taken to a non-licensed site; and
- Contact the Site Manager in the event that site wastes are not taken to a licensed waste disposal or recycling facility.

Keep Legislative Records:

- Retain copies of all relevant permits or licences for both carriers and disposal sites;
- Use consignment notes for the off-site disposal of all hazardous wastes;
- Retain all WTNs for at least three years;
- Record contact details for all waste carriers and disposal sites;
- Keep audit reports;
- Maintain recycling receipts for non-hazardous waste; and
- Record a description of all waste removed from site including volume and consignment route number.

Monitoring:

- Track the volumes of waste produced using key performance indicators (KPIs) and compare this against targets which will be set at the beginning of the project.

2.6 Water Quality and Pollution Management

If groundwater pumping / dewatering is required then applications will be made by the contractor before the abstraction or impoundment commences as appropriate to the Environment Agency in accordance with the Water Resources Act 1991 (as amended by the Water Act 2003), Environment Act 1995, Water Resources (Abstraction and Impounding) Regulations 2006.



If water discharge activities are required then an application for water discharge activity environmental permit will be made by the contractor to the Environment Agency before water is discharged in accordance with the Environmental Permitting (England and Wales) Regulations 2016.

2.6.1 Outlined below are recommendations for mitigation measures to be implemented during construction to control water quality impacts. These mitigation measures take due cognisance of the Water Resources Act 1991 (UK Government, 1991) and the Construction Industry Research and Information Association Report C532 (CIRIA, 2006).

2.6.2 Good practice measures set out in the relevant Pollution Prevention Guidance (PPGs) (Environment Agency et al., 2010) or the updated versions, Guidance for Pollution Prevention (GPPs) (Natural Resources Wales et al., 2017), have been followed. The relevant guidance includes:

- GPP 5: Works and maintenance in or near water
- PPG 6: Working at construction and demolition sites
- PPG 7: The safe operation of refuelling facilities
- GPP 13: Vehicle washing and cleaning
- GPP 21: Pollution incident response planning
- GPP 22: Dealing with spills

2.6.3 General mitigation:

- Undertake a pollution risk assessment of the site and the proposed activities;
- Identify all Controlled Waters that may be affected by the works and temporary discharge points to the on-site drainage ditches and the marine environment;
- Implement a pollution control system during earthworks and construction; and
- Monitor construction procedures to ensure management of risk is maintained.

2.6.4 Specific mitigation measures include:

- In accordance with the Environment Agency's scoping requirements, there will be a minimum 8m buffer, where a works stand off will apply, along all on Site watercourses (with the exception of water crossings).
- Turfs within the stand off buffer shall be maintained intact and undisturbed throughout the construction phase, thus forming a vegetated filter strip, providing protection to the watercourses from silt and run-off.
- These vegetated filter strips shall be protected during the works by use of silt fencing, barrier fencing, soil berm or similar to clearly demarcate the stand-off areas and to provide a barrier to movement of plant and migration of silt as required.



Soil stockpiles to be located away from overland flow paths and water bodies, and outside of the SAC catchment, and to be seeded as soon as possible, covered with geotextile mats and/or surrounded by a bund.

2.6.5 The Site is of an undulating topography and as a precautionary the following additional considerations and measures will be implemented to sever pathways between the construction works and any watercourse:

- Phasing of works, particularly of turf and topsoil strip, such that as little bare soil is exposed at any one time.
- Sealing of all soils in storage areas (stockpiles) using an excavator bucket at the end of each shift, to minimise the potential for sediment to be washed off during a rainfall event.
- No stockpiles will be located within the buffer strip.
- Where long-term storage of soil is planned, vegetation on stockpiles shall be allowed to naturally regenerate and/ or be seeded to facilitate a cover of vegetation.
- If required, a combination of ditches, berms and sediment traps can be employed in order to control the direction and to slow the flow of rainwater run-off.
- Diversion of surface water from areas of bare soil into freely draining pond/ lagoon areas to enable it to drain to ground. Where volumes and infiltration rates prevent this, water will be allowed to drain to the watercourses only if it is suitably free of visual evidence of silt or other contamination. The vegetated buffer along the watercourse will act as a filter strip but should also be supplemented with silt fencing to ensure no water pollution occurs.
- Where water is visibly turbid (silt-laden) or impacted by contaminants, it shall be treated prior to discharge using one or a combination of; a proprietary water treatment system (e.g. silt-buster); hay bale and/ or sediment weirs or mats or similar; temporary grips and/ or; proprietary silt filtration devices (e.g. Naylor's SmartFilter).
- Any temporary site drainage system to be developed to prevent silt-laden run-off being discharged into sewers or surface watercourses.
- The weather forecast will be monitored daily by the Principal Contractor throughout the project, in order to predict periods of likely heavy rainfall. Where heavy rainfall is predicted works may need to be suspended. Ahead of a period of forecasted heavy rain, the site works will be inspected to identify areas susceptible to sediment run-off and implement additional precautions as necessary. Such precautions may include additional sediment trap weirs, or covering of stockpiles.
- All proposed trackway crossings are to use existing agricultural access points and as such no new crossings above those in the design are proposed. At each trackway crossing point measures shall be put in place prior to the start of works in that area. Examples of such measures shall be designed by the Principal Contractor or sub-



contractors and shall include use of silt fencing on either side of the track across the top of the crossing.

- Use of silt control measures within the watercourse, such as bales, booms, sedimats or other measures to control any spread of silt should it enter the watercourse.
- Use of edge-protection berms to prevent migration of silt sideways from trackway into watercourse.
- In relation to land drains (C4 in Table 8.7 of the ES), if required, the Applicant will replace or repair any land drains found to be damaged during construction.
- Avoidance of site run-off of water or mud. Best practices measures for silt/runoff, pollution prevention measures and groundwater/other hydrological maintenance during piling and other works in close proximity to watercourses such as silt traps, bunds, interception features.

2.6.6 Proposed mitigation for concrete works:

- If concrete is brought to site, provide dedicated concrete washout skip/basin to prevent any uncontrolled spilling of material in-site or nearby public roads;
- Concrete washout facilities to be regular maintained and solids to be disposed of safely;
- If on-site concrete batching is needed, ensure necessary containment measures are in place and suitable disposal and cleaning methods;
- Robust emergency response in place for any concrete spillage on site;
- Correct disposal of any waste or surplus concrete in agreed suitable locations both onsite and offsite;
- Where applicable, shuttered pours should be used to prevent on concrete losses to ground;
- Ensure excavations are sufficiently dewatered before concreting begins and that dewatering continues while concrete sets;
- Tools and plant to be washed and cleaned in designated areas within the Site compound (including designated concrete wash-out areas) where runoff can be isolated for treatment before discharge to watercourse/ground or sewer under appropriate consent; and
- Cover freshly poured concrete surfaces to prevent any polluted runoff attributed with wet weather.

2.6.7 Implement appropriate fuel and chemical storage measures:

- Follow measures set out in the 'Storage of Plant and Materials' section of the outline CEMP;
- Maintain oil booms and absorbent pads within all work areas;
- Fuel and oil deliveries to take place on an impermeable transfer area with a bunding facility capable of handling a major spill;



- Assign designated refuelling areas where appropriate and site them as far as practicably possible and at least 20m from adjacent field drains and public sewers;
- Fuel and other potentially polluting chemicals to be stored in a secure impermeable and bunded storage area outside the River Mease SAC catchment; and
- Install operational drainage as early as possible with the inclusion of oil separators.

2.6.8 Establish contingency planning and emergency procedures:

- All pollution prevention consumables and plant to be made readily available at all times. Keep spill kits in all vehicles to enable a rapid and effective response to any accidental spillage or discharge.
- Train all construction staff in the effective use of spill kits and raise awareness of all preventative measures for water pollution. Train all staff to use emergency response equipment.
- An emergency response plan will be prepared as part of the CEMP and prior to construction. The emergency response plan will include (but not be limited to) chemical/fuel spillage, flood events, fire, explosions, structural collapse.

2.6.9 Surface Water

- Sediment and erosion control – using grass and vegetation as natural filters, works timings i.e. don't strip the site and undertake earthworks in the winter, only strip what is necessary, dust suppression etc.
- Runoff management – divert water away from the construction area(s) before it can pick up sediment/ silt. Settlement should be a secondary measure where needed. Control surface water runoff, including from damping down, to prevent contamination of waterbodies.
- Stormwater management – attenuation, settlement and 'slowing the flow' as far as possible.
- Monitoring and maintenance procedures – weather forecasting, emergency arrangements.
- Discharges of water abstracted from excavations/ or dewatering of aquifers to be subject to quality attenuation measures as required.
- Within the River Mease SAC catchment, increased provision of attenuation measures to reduce surface run-off and nutrient enrichment. This will provide water quality benefits to minor watercourses and ditches in the locality. Avoidance and mitigation measures as detailed in HRA and best practice measures as detailed throughout the CEMP.
- The proposed drainage strategy is detailed in the appended FRA (see Appendix C). As far as possible and in accordance with SuDS best practice, the key principle of the strategy is source control whereby all surface water run-off is discharged to ground as close to the point of interception as possible. This will include: Solar panel arrays will allow incidental run-off to infiltrate to ground below the panels. All trackways constructed to be permeable (i.e. unsealed), and as such will maintain



infiltration capacity similar to the bare soil cover under the current scenario. The proportion of land given over to trackways is significantly smaller than that currently left as bare soil thus this represents a significant betterment. Where concrete pads are required a gravel-filled drainage trench shall be constructed around the structure, thus providing soakaway capacity equivalent to the infiltration capacity lost beneath the structure.

- As detailed in the FRA in Appendix C, parts of the Proposed Development remain at risk of flooding from surface water, including from small channels and ditches within the Site. The flood depth in these areas is expected to be less than 300mm. Solar panels are unlikely to be affected by this flooding, should it occur, and no specific mitigation is required to protect them other than ensuring the bottom edge of the panels is not within 300mm of the ground within the mapped surface water flood risk area. As the lowest part of the solar panels is to be 800mm above ground level, there is sufficient height above the estimated potential flood level that is predicted to affect the northern section of panels only.
- With the exception of the BESS and the Proposed Development's substation compounds, all run-off from the proposed structures will be dealt with locally with source control measures, whereby all surface water run-off is discharged to ground as close to the point of interception as possible, as detailed in the FRA (see Appendix C) and the Site will not generate extra run-off.
- To mitigate risks from contaminated water during a fire event at the BESS and the Proposed Development's substation compounds, these areas will be mostly impermeable, with water diverted into an underground storage area which can be isolated if required. The BESS will comprise a 100% impermeable sub-base with drainage infrastructure built into or below the sub-base to divert runoff to a lined contaminant tank/pond in the unlikely event of a battery fire. Once in the tank testing, flow control and pumping will ensure the safe discharge and removal of the water. Control valves will be engaged at the earliest detection of a fire to initiate release of the surface and fire water contaminant. Approximately 20% of the Proposed Development's substation footprint will be comprised of impermeable material. The remaining 80% of the Proposed Development's substation footprint can be considered permeable with a gravel sub-base that will allow natural drainage/infiltration. During normal rainfall events surface water will bypass these tanks will be discharged at a rate limited to the greenfield runoff rates for the same event, with outfalls into the drainage ditch approximately 300m northwest of the compounds as detailed in the FRA (see Appendix C). In the event of a fire, the tanks will be isolated and the water contained until tested. If the water is tested and confirmed to be contaminated, the water will be removed from the tankers by specialists and disposed of at an appropriate facility rather than into the environment.
- To mitigate a potential increase in flows/volumes due to reduced attenuation with the increase in impermeable surfaces, the storage areas at the BESS and the Proposed Development's substation compounds may include water flow



technology, such as a Hydrobrake, to reduce outflows to the greenfield runoff rates for the same event.

- The Proposed Development has been designed to avoid fluvial flood risk zones associated with the unnamed watercourse which meanders through the Site. Potential surface water (pluvial) flood risk has been mitigated through design in three ways: All infrastructure such as the BESS and the Proposed Development's substation will be raised with a void beneath. The vast extent of the Site includes elevated solar panels on discrete piled foundations. The proposed cable route between the Proposed Development and its connection to the National Grid Drakelow substation will be entirely underground, and therefore there will be no above ground structures relating to the cable route to impede surface water runoff.

These mitigation measures will be detailed collaboratively with the appointed contractor and provide in a comprehensive Water Quality and Silt Management Plan in the final CEMP. This will:

- Identify personnel responsible for protecting water quality and preventing silt from entering water courses
- Provide a map showing the location of all watercourses in and within 50m of the site boundary
- Describe the proposed works that have the potential to affect water quality and generate silt;
- Provide a full schedule of mitigation measures to be implemented at specific phases and locations of the development;
- Demarked an 8m offset from all watercourses (except where crossings are required)
- Provide a programme for regular monitoring of watercourses
- Set out a remedial action plan should a water quality or silt deposition event occur

2.7 Climate Change

2.7.1 The Proposed Development has the potential to generate impacts on climate change due to:

- Greenhouse Gas (GHG) emissions from construction traffic and equipment;
- Use of natural resources in construction materials; and
- Increased flood risk on-site due to climate change needing to be considered in the design.

2.7.2 Consideration has been given to measures to cope with climate change at the Site, for example by planting resilient plant species so as to exploit the opportunity climate change presents to create 'valuable new landscapes', in line with Natural England guidance.



- 2.7.3 The ecological mitigation and enhancements within the Proposed Development (see ES Appendix 5.6: Outline Landscape and Ecological Management Plan) will increase resilience to the ecological effects of climate change, through the creation and enhancements of hedgerows, creation of woodland understory planting with trees, including along the river corridor to the north of the Oaklands Farm area as well as creation of meadows along the field margins and in more open areas. This will improve ecological connectivity within the Site therefore increasing the ability of species to move and adapt, via the provision of habitats of high ecological value and/or those which provide a clear ecosystem service such as carbon storage through tree planting and improvements in relation to water and soil erosion through the provision of attenuation measures. In addition, the creation of new habitats noted above, and the provision of bird and bat boxes will be beneficial for both bat and bird species offering both new shelter and foraging opportunities.
- 2.7.4 As temperatures are projected to increase along with the frequency and intensity of winter storms, this brings an increased risk of discomfort, particularly for permanent employees working at the Proposed Development during its operational life. To avoid employee discomfort, for example during periods of extreme temperatures or increased precipitation, construction and operational activities will be managed so that the hottest or wettest/coldest parts of the day are avoided to ensure worker safety, although it is noted that this may not always be possible during the construction phase. The design, orientation and positioning of welfare facilities for staff will also be carefully considered. Additionally, the risk of overheating/hypothermia will be incorporated into the Site risk assessment and the Proposed Development will comply with all relevant UK legislation related to the work environment including The Health and Safety at Work etc. Act 1974 and The Management of Health and Safety at Work Regulations 1999. This will include measures such as ensuring appropriate personal protective equipment (PPE) is worn for the Site conditions and adequate water supplies are available to ensure staff stay hydrated during hotter weather.
- 2.7.5 Appropriate standard and good practice control measures will include:
- Designing, constructing and implementing the Proposed Development in such a way as to minimise the creation of waste and maximise the use of alternative materials with lower embodied carbon, such as locally sourced products and materials with a higher recycled content where feasible;
 - Reusing suitable infrastructure and resources already available in the Site where possible to minimise the use of natural resources and unnecessary materials (e.g. reusing excavated soil for fill requirements);
 - Develop a Travel Plan to reduce the volume of construction staff and employee trips to include the potential to implement staff minibuses and car sharing options.
 - Switching off vehicles and plant when not in use and ensuring construction vehicles conform to current UK emissions standards.



- Conducting regular planned maintenance of the Proposed Development to optimise efficiency.
- Enrolling in the Considerate Constructors Scheme (CCS) to assist in reducing pollution, including GHGs, from the Proposed Development by employing good industry practice measures.

2.8 Ecology Management

2.8.1 Any development within the Site should ensure that valuable habitat areas are protected or reinstated and, where appropriate, enhanced to ensure opportunities for net gain in biodiversity.

Best practice guidelines (CIEEM, 2022) should be followed throughout the construction of the proposed development to protect existing wildlife and habitats within the site. This includes obtaining appropriate species licences prior to the commencement of works, and implementing mitigation strategies to ensure compliance with relevant wildlife legislation.

A separate Landscape and Ecology Management Plan (LEMP) has been prepared to set out how the Developer will specifically protect and enhance ecological interests through operation of the proposed development (Appendix 5.6 of ES).

Construction activities will take place with adherence to detailed mitigation measures as described in Appendix 17.1 Schedule of Mitigation in Volume 3 of the ES. A Species Protection Plan will be included in the final CEMP and will:

- Identify personnel with protected species responsibilities including a suitably qualified ecologist as an appointed Ecological Clerk of Works;
- Provide a plan identifying the suitable habitat for protected species within the site;
- Outline the construction activities that have the potential to affect protected species;
- Provide the results of pre-commencement species surveys
- Set out the measures to protect habitats during construction
- Set out the measures to protect species during construction
- Set out how the protection measures will be monitored

2.8.2 Pre-construction protected species surveys will be undertaken prior to any works commencing on site and the final CEMP and LEMP updated in line with the findings (including badger, otter, bat roost assessment of trees, nesting birds (should vegetation removal be required within the breeding bird season), invasive non-native species (incl. Japanese Knotweed) and other protected species surveys if deemed necessary following initial habitat surveys). Measures to protect habitats and species include:



- Specific surveys will be undertaken within suitable timeframes prior to commencement of construction (subject to the habitat features present), or within a suitable timeframe to support NE species licensing, including the following: Habitat survey to determine whether conditions have changed as a result of changes in land management (and implications for protected species surveys).
- Marking out sensitive habitats and restricting construction works within 30m of, for example, an badger sett (sensitive timing of works (e.g., during breeding season between November and June inclusive)) or otter holt. Marking and protective fencing of Japanese Knotweed will be installed prior to works.
- Any works undertaken within 30m of a badger sett which cannot be avoided, will be completed under a Natural England badger disturbance licence as necessary. Mitigation measures required under the licence may include timing of works to avoid the breeding season and adapting working methods to minimise disturbance.
- Any vehicle activity within close proximity of sensitive habitats (e.g., badger setts, otter holt) will be subject to a 5 mile per hour (mph) speed limit.
- Tool box talks for site workers to raise awareness of ecological issues on site (including badger, invasive species). This will cover measures such as safe storage of materials and substances, measures to prevent mammals becoming trapped in excavations or materials, and control measures including construction traffic speed controls.
- Pre-inspection checks for otter signs in the vicinity of works and appropriate working practices to avoid disturbance including no night-time working (unless unavoidable), sensitive construction lighting and appropriate working buffers.
- If identified during pre-construction surveys, best practice working methods with regard to invasive species will be specified in the CEMP. Pre-construction inspections for invasive non-native species and, if required, the provision of appropriate buffer zones and an eradication programme. Any invasive species within or adjacent to the Site will be demarcated prior to works and will be subject to chemical/manual treatment prior to and during works in accordance with a CEMP, with long-term eradication prescriptions to be detailed and implemented through a LEMP.
- Safe storage of materials and substances, measures to prevent mammals from entering construction activities within the Site and becoming trapped in excavations or materials, and control measures including construction traffic speed controls. Any exposed pipe systems when contractors are off site will be capped or exit ramps provided from any exposed trenches or holes.
- Any invasive species within or adjacent to the Site will be demarcated prior to works and will be subject to chemical/manual treatment prior to and during works, with long-term eradication prescriptions to be detailed and implemented through the LEMP.
- Trees identified as having low bat roost suitability will be felled using soft felling techniques. This will involve the section felling of trees and then gently lowering



each section in a controlled manner to ground. The sections will be left for at least 24 hours with the features in an upright position to enable bats to vacate. This would be completed at a sensitive time of year in spring/autumn to avoid the breeding season.

- Trees identified as having moderate and high bat roost suitability will be retained. If required, best practice construction methods will be detailed in the CEMP.
- Suitable bird nesting habitat, including hedgerows and trees that will be removed as part of the Proposed Development will be undertaken outside of the bird nesting season between March and August (inclusive). Where this is not feasible, the removal of these habitats will be completed under a watching brief by an ECoW.
- Where clearance of suitable habitat is programmed during the bird breeding season (including skylark), prior to works, a suitably qualified person must undertake a survey to determine whether birds are nesting in the area. If a nest is discovered, clearance or other construction works would need to be delayed within an exclusion zone. Works may only recommence once it is confirmed that chicks have fledged and that no other nests are in use within the exclusion zone. Best practice construction methods will be detailed in the CEMP and timing of any works will be sensitive.

2.8.3 Existing trees and hedgerows will be protected in accordance with best practice (BS 5837:2012. Trees in Relation to design, demolition and constructions - Recommendations) during the construction period. Requirements within the Arboricultural Impact Assessment (Appendix 6.14 of Volume 3 of the ES) will be adhered to. This will include a protection buffer of at least 15m from ancient woodland associated with Grove Wood LWS to the north of the Park Farm area and which lies in close proximity to the proposed cabling route and for any ancient or veteran trees a buffer zone at least 15 times larger than the diameter of the tree.

2.8.4 Any works that have potential to affect habitats suitable for reptiles such as at Drakelow Power Station or field edges, or known populations of reptiles will be required to undertake the following ecological protection measures: A series of habitat manipulation measures will be implemented to reduce the suitability of the Site for reptiles. These would include strimming any areas of long grass to a height of no more than 15cm during the reptile active season (April to October inclusive). Construction sites can rapidly increase in suitability for reptiles if left unmanaged; therefore, it is important that the habitat manipulation measures are maintained, particularly in the grassland, to prevent reptiles from moving into the Site. In addition, any soils or earth removed and stockpiled as part of proposed works to implement the solar arrays, should be sealed off to prevent any reptiles from using this as a place of refuge and subsequently being injured or killed as a result of movement of materials. If suitable habitats for reptiles such as refugia are removed, they should first be subjected to a destructive search by a suitably qualified ecologist immediately prior to removal.



2.9 Archaeological Management

- 2.9.1 Any works to be undertaken will be covered by a Written Scheme of Investigation (WSI) which will detail the scope of works and how they are to be executed and monitored. The WSI will be agreed with the appropriate body and, at the time of writing, this is assumed to be the Derbyshire County Council (DCC) Archaeologist acting as archaeological advisor to Soth Derbyshire District Council (SDDC).
- 2.9.2 Good practice measures will be designed once consultation on the results of evaluation (e.g., geophysical survey) has been completed with the DCC Archaeological Officer, as archaeological advisor to SDDC. The Site has been subject to geophysical survey, following statutory consultation stage, to refine understanding of the presence and extent of hitherto unrecorded below-ground heritage assets (reporting supplied as ES Appendix 7.2). Without prejudice to the CEMP content, it is likely that measures relating to archaeological monitoring of zones of groundworks (e.g. for substation and BESS) and control measures to avoid accidental damage to heritage assets (e.g. arising from vehicle movements in the vicinity of the Park Farm listed building) are likely to be included.
- 2.9.3 A suitable programme of mitigation to address harm to, or loss of, assets would be drawn up in consultation with the DCC Archaeological Officer, as archaeological advisor to SDDC. This is likely to comprise a staged programme of archaeological works (e.g., fieldwork) secured by Requirement of the DCO and will be detailed in a WSI agreed via consultation with the DCC Archaeological Officer. This mitigation will not reduce the level of effects to the heritage assets but will provide a record of the features lost as a result of development, preserving them by record. This follows industry best-practice to address effects to heritage assets.
- 2.9.4 No construction activities may commence until the implementation of the works outlined in this WSI, or without the agreement of DCC.
- 2.9.5 If an unexpected archaeological find is discovered during the course of construction activities, work will stop immediately and must be reported to the technical specialist and DCC's Archaeological officer. Works must stop until the appropriate mitigation has been undertaken and statutory consent for works to recommence from DCC has been given.
- 2.9.6 Prior to construction, a programme of temporary protective fencing, or barriers, should be employed along the site boundary adjacent to the Grade II Listed Grove Farmhouse (NHLE 1096453), in order to prevent accidental damages resulting from the movement of plant and the installation of solar panels. These protective measures may be removed following the completion of construction
- 2.9.7 As stated in Chapter 7 of the ES, assets of later prehistoric to Roman date of demonstrably equivalent value to designated heritage assets are considered unlikely. Should however, any be present, they could be subject to harm. If an asset



is identified and harm is anticipated, mitigation would be implemented via the CEMP and the WSI, secured by DCO Requirement 18.

2.9.8 The Applicant will be able to micro-site certain elements of the Proposed Development (such as transformer stations, fencing and access tracks), but in situations where micro-siting will not wholly avoid or alleviate impacts to archaeological discoveries on site, the Applicant will use alternative construction methods to protect archaeological assets, where required. Piling for the solar panel support structures will cover a large portion of the site and micro-siting will likely only be required for very small areas. However, instead of piling for the solar panel support structures, the structures can be fastened to concrete pads placed over sensitive archaeological assets to protect them from intrusive piling. This method and proposed locations will be identified in the WSI, secured by the DCO Requirement 18.

2.10 Public Right of Way (PRoW) Management Plan

2.10.1 Construction works would directly affect the Cross Britain Way/National Forest Way running through the north of the Oaklands Farm area. During construction of the access tracks, it is not considered necessary to divert those sections of PRoW closest to the access track route.

2.10.2 Crossing points at PRoW will be manned by a site operative to ensure site vehicles do not come into conflict with users of the PRoW. Gates will be erected to prevent members of the public accessing the Site, and to allow vehicles to cross the PRoW safely. There may be a slight delay before walkers can cross the Site while the working area is made safe.

2.10.3 These gates would be used by the operatives to allow site vehicles across the PRoW when it is safe to do so. If there are users of the PRoW approaching a crossing, they would get priority to continue their journey unless a vehicle was already in the process of crossing.

Out of working hours, the PRoW would remain open and accessible. A strict speed limit of 15 miles per hour (mph) on surfaced and 10 mph on unsurfaced haul roads and work areas will also be implemented on site during the construction works.

A Public Rights of Way Management Plan is secured through a Requirement with the DCO and will also be provided within the final CEMP for ease of reference. The Public Rights of Way Management Plan will:

- Identify personnel responsible for safeguarding users of the Cross Britain Way and public safety;
- Provide a clear plan showing the location of the PRoW and where it will be affected
- Detail the construction hours of the project



- Set out a schedule of measures to be employed to safeguard users of the PRow for the entire construction period
 -
- 2.10.4 A proposed permissive path has been included in the application, to connect existing PRow in the local area. It will connect the Cross Britain Way with footpaths SD13/4/1 and SD/13/1/1 to the south-east of the Oaklands Farm area. The route is shown in ES Appendix 5.6: Outline Landscape and Ecological Management Plan. The permissive path will be linked into the wider landscape and ecological management of the Site with hedgerow and wildflower planting adding to the visual and biodiversity value of the path. An interpretation board on solar energy will be provided and is included in ES Appendix 5.6: Outline Landscape and Ecological Management Plan.
- 2.10.5 The Proposed Development could provide a valuable educational resource for the local area and could be visited by schools and local community groups using the Cross Britain Way and proposed permissive path.

3. Environmental Management Plans

- 3.1.1 A number of complementary environmental plans and procedures have been included within the DCO application and set out proposed mitigation for the construction phase, and in some cases the operational phase. These documents include:
- Construction Traffic Management Plan (CTMP) (see Appendix 10.1 in Volume 3 of the ES).
 - Outline Landscape and Ecology Management Plan (LEMP) (see Appendix 5.6 in Volume 3 of the ES);
 - Outline Soils Resource Management Plan (SRMP) [**Appendix 1** of this OCEMP]; and,
 - Outline Battery Safety Management Plan (see Appendix 4.6 in Volume 3 of the ES).



References

Literature

Bat Conservation Trust. (2018). Bats and Lighting in the UK: Bats and the Built Environment Series.

British Standards Institution. (2014). Code of practice for noise and vibration control on construction and open sites BS 5228-1:2009+A1:2014.

Chartered Institute of Ecology and Environmental Management (2018). Guidelines for Ecological Impact Assessment in the UK and Ireland: Terrestrial, Freshwater, Coastal and Marine. Version 1.1. (Updated 2019). Available at:

<https://cieem.net/resource/guidelines-for-ecological-impact-assessment-ecia/>

Construction Industry Research and Information Association. (2001). Control of water pollution from construction sites. Guidance for consultants and contractors C532.

Environment Agency in England and Wales, Northern Ireland Environment Agency and Scottish Environment Protection Agency. (2010). PPG 6: Working at construction and demolition sites. Available at: <https://www.netregs.org.uk/media/1672/ppg-6.pdf>

Environment Agency in England and Wales, Northern Ireland Environment Agency and Scottish Environment Protection Agency. (2010). PPG 7: The safe operation of refuelling facilities. Available at: <https://www.netregs.org.uk/media/1673/ppg-7.pdf>

Historic Environment Scotland. (2019). Historic Environment Policy for Scotland. Available at: <https://www.historicenvironment.scot/advice-and-support/planning-and-guidance/historic-environment-policy-for-scotland-heps/>

Historic Environment Scotland (2019b). Designation Policy and Selection Guidance. Available at: <https://www.historicenvironment.scot/archives-and-research/publications/publication/?publicationId=8d8bbaeb-ce5a-46c1-a558-aa2500ff7d3b>

Institute of Air Quality Management. (2019). Guidance on the assessment of dust from demolition and construction. Available at: <https://iaqm.co.uk/guidance/>

Institute of Lighting Professions. (2011). Guidance Notes for the Reduction of Obtrusive Light GN01:2011.

Natural Resources Wales, the Northern Ireland Environment Agency, and the Scottish Environment Protection Agency. (2017). GPP 5: Works and maintenance in or near water. Available at: https://www.netregs.org.uk/media/1418/gpp-5-works-and-maintenance-in-or-near-water.pdf?utm_source=website&utm_medium=social&utm_campaign=GPP5%2027112017

Natural Resources Wales, the Northern Ireland Environment Agency, and the Scottish Environment Protection Agency. (2017). GPP 13: Vehicle washing and cleaning. Available at: <https://www.netregs.org.uk/media/1414/gpp-13-v2-plussepa-plusniea-plusnrw.pdf>



Natural Resources Wales, the Northern Ireland Environment Agency, and the Scottish Environment Protection Agency. (2017). GPP 21: Pollution incident response planning. Available at: <https://www.netregs.org.uk/media/1436/gpp-21-final.pdf>

Natural Resources Wales, the Northern Ireland Environment Agency, and the Scottish Environment Protection Agency. (2018). GPP 22: Dealing with spills. Available at: <https://www.netregs.org.uk/media/1643/gpp-22-dealing-with-spills.pdf>

Scottish Environmental Protection Agency. (2007). Controlling Light Pollution and Reducing Lighting Energy Consumption. Available at: <https://www.webarchive.org.uk/wayback/archive/20180520162507/http://www.gov.scot/Publications/2007/03/14164512/13>

Legislation

UK Government. (1990). Environmental Protection Act. Available at: <https://www.legislation.gov.uk/ukpga/1990/43/contentse.g>.

UK Government. (1974). Control of Pollution Act. Available at: <https://www.legislation.gov.uk/ukpga/1974/40>



Appendix 1 Outline Soil Management plan

1. Introduction

- 1.1.1 The Outline Soil Management Plan (OSMP) sets out principles and procedures for good practice (embedded mitigation measures) and bespoke mitigation measures in soil handling, storage and reinstatement to be used for the Proposed Development. This outline plan describes the principles that the Principal Contractor will follow to minimise adverse effects on the nature and quality of the soil.
- 1.1.2 To secure effective delivery of the OSMP, the Contractor must implement it through site-specific soil management method statements (or similar) for the construction phase. The works must also be monitored to audit compliance with the OSMP (and location-specific construction method statements); and to allow ongoing advice on soil handling to be provided. The OSMP is based upon guidance such as the Department for Environment, Food and Rural Affairs (Defra's) Construction Code of Practice for the Sustainable Use of Soils on Construction Sites (Ref: 1-1); the Ministry of Agriculture, Fisheries and Food's (MAFF's) Good Practice Guide for Handling Soils (Ref: 1-2), and the Institute of Quarrying (2021) Good Practice Guide for Handling Soils in Mineral Workings
- 1.1.3 The OSMP assumes that all mitigation measures pertaining to protected species and other environmental issues are in place, such that the soil stripping, storage and reinstatement operations can proceed.

The OSMP is considered to be a 'live document' to be updated as further information becomes available. The OSMP will be revised prior to commencement of construction operations to consider the site-specific soils data collated by the appointed specialist agricultural land drainage consultant as part of the agricultural drainage design works.

1.2 Roles and Responsibilities

- 1.2.1 The effective implementation of the OSMP requires that roles and responsibilities are clearly defined and understood. Specific job titles, roles and responsibilities will be defined by the Contractor in the location specific construction management plans; however, the roles and responsibilities are expected to be similar to those described below, as described in the Construction Environmental Management Plan (CEMP).

1.2.2 Construction Manager

- 1.2.3 Responsible to the Project Manager for:
 - Determining and sourcing the plant and equipment to be used;



- Ensuring that working areas, services and stockpiles are clearly marked;
- Ensuring that records are maintained; and
- Ensuring that staff receive appropriate training regarding soil handling issues such as stop conditions and soil testing requirements.

1.2.4 Site Foreman

1.2.5 Responsible to the Construction Manager for:

- Implementing the site-specific construction soil management method statements to manage soil handling and storage on site to ensure the sustainable use of the soil resource;
- Ensuring daily records of weather conditions, stoppages and soil plasticity (moisture) testing are made and kept;
- Ensuring that works are carried out safely, under correct conditions and in compliance with wider environmental requirements; and
- Ensuring that the protection of services is maintained during the soil handling works.

1.2.6 Safety Advisor

1.2.7 The safety adviser is responsible to the Project Manager for:

- Ensuring the plant operators have the relevant training and certification.

1.3 Soil Resource

1.3.1 The erodibility of a soil (susceptibility to damage and loss) influences the level of mitigation required to protect it and the measures to be put in place through the OSMP and site-specific construction method statements.

1.3.2 Soils with low risk of erosion

1.3.3 Good practice (embedded mitigation) measures following those recommended in Defra's Construction Code of Practice for the Sustainable Use of Soils on Construction Sites (Ref: 1-1); MAFF's Good Practice Guide for Handling Soils (Ref: 1-2), will provide appropriate protection to these soils as they are generally more resistant to damage and loss.

1.3.4 Soils with moderate risk of erosion

1.3.5 Good practice (embedded mitigation) measures will mostly provide appropriate protection to these soils, however damage is likely to occur if worked in less than ideal conditions, for example when the soils are wet. Therefore, on a location by location basis, depending upon factors such as physical soil properties and local topography, bespoke mitigation measures may be required. The soils should be given appropriate consideration because of their importance for agricultural production.



1.3.6 Soils with high risk of erosion

1.3.7 Development on those soils should be avoided if possible, however where this is not possible, they require special consideration and careful planning of construction methods, i.e. bespoke mitigation measures, in order to preserve their structure and function.

1.4 Good Practice Mitigation

1.4.1 General principles of soil handling

1.4.2 Unlike under the current land management scenario, during the operational phase of the Proposed Development, the fields will not be accessed by heavy plant or machinery, thus reducing compaction effects on the soil.

1.4.3 The main threats to soil resources at construction sites are trafficking of vehicles/plant and incorrect handling, which can cause damage to soil structure through compaction and smearing (both effects are sometimes referred to as deformation). These effects compromise the ability of the soil to perform its functions, such as providing adequate amounts of water, air and nutrients to plant roots. The risk of compaction and smearing increases with soil wetness. To minimise the risk of damage to soil structure, the following main rules must be observed during all soil handling tasks:

- No trafficking/driving of vehicles/plant or materials storage to occur outside designated areas.
- No trafficking/driving of vehicles/plant on reinstated soil (topsoil or subsoil).
- Only direct movement of soil from donor to receptor areas (no triple handling and/or ad hoc storage).
- No soil handling to be carried out when the soil moisture content is above the lower plastic limit.
- Soils should only be moved under the driest practicable conditions and this must take account of prevailing weather conditions. (see rainfall “stop” criteria in paragraph 3.5.2).
- No mixing of topsoil with subsoil, or of soil with other materials.
- Soil only to be stored in designated soil storage areas.
- Plant and machinery only work when ground or soil surface conditions enable their maximum operating efficiency.
- All plant and machinery must always be maintained in a safe and efficient working condition.
- Daily records of operations undertaken, and site and soil conditions should be maintained (see section 5 for the summary of monitoring and record keeping schedule).



- Low ground pressure (LGP models) and tracked vehicles should be used where possible. This will greatly minimise the extent and/or intensity of the soil loosening required after restoration. Consequently, it will reduce the costs and potential delays due to the need for additional soil cultivation.
 - To limit the number of vehicle movements, material, such as soil, generated on Site will be re-used, where possible, within other areas of the Site.
 - The installation of the solar panels, will so far as possible, avoid periods of unsuitable weather when soil is likely to be unsuitable for trafficking. Heavy rainfall can affect ground conditions even in summer. So far as possible, trafficking over the land will only take place when the ground is adequately dry, but that is not always possible. The machinery involved in installing the panels is generally smaller than farm machinery, and no long-term damage is likely to ensue.
- 1.4.4 The location-specific methods statements (or similar) must be defined based on the results of detailed site-specific soil survey.
- 1.4.5 The survey results should be used to specify in detail:
- The ‘before’ statement of physical characteristic of the soil to be disturbed;
 - where bespoke mitigation measures are required, and what these bespoke measure entail;
 - the depth and properties of topsoil; and
 - the depth of subsoil and presence of any distinct soil horizons.

1.5 Stop conditions

1.5.1 Adverse weather

1.5.2 In certain weather conditions, the handling of topsoil and subsoil must be effectively managed to prevent damage. Topsoil and subsoil handling must cease applying the following criteria:

- in drizzle and/or intermittent light rain, handling can continue for up to four hours unless the soils are already in a plastic state (see paragraph 1.5.6);
 - if there is heavy rain (e.g. heavy showers, slow moving depressions), handling must stop immediately;
 - soil shall not be handled or trafficked over/driven on immediately after a heavy rainfall (or snow/hail) in a waterlogged condition, or when there are standing pools of water on the soil surface.
 - If the works are interrupted by a rainfall event, soil stripping should be suspended; and where the soil profile has already been disturbed, the works should be completed to the base level in that location.
- 1.5.3 Additionally, soil should not be handled or trafficked over/driven on when the ground is frozen or covered by snow.

1.5.4 The above criteria should be clearly understood by all personnel.



1.5.5 Soil conditions

- 1.5.6 Irrespective of the weather, soils should not be handled when in a plastic state (when moisture content exceeds their lower plastic limit); and as a general rule should be dry when handled.
- 1.5.7 If the soil is excavated and placed in stockpiles when wet (above the plastic limit), they are easily compacted by the machinery handling them, or by the weight of the soil above it in the stockpile. As well as this damage to soil structure, when soils within a stockpile are compacted, the core of the stockpile remains anaerobic throughout the storage period. This damage results in the soil being very difficult to handle and re-spread at the time of reinstatement (i.e. it will not be in a friable state and will not break down into a suitable tilth). In this case, in order to achieve the required standard of restoration, a period of drying and appropriate additional cultivation is required (to repair soil structure and re-aerate the soil) to ensure the soil is acceptable for planting. The costs of these unplanned operations, and consequent delays to the programme of works, could be substantially, if not several times, greater than the costs of ensuring that the soil stripping and stockpiling operations are carried out in optimum conditions and making allowances for delays due to bad weather.
- 1.5.8 For arable land, the period where the soil conditions will generally be the driest typically occur in the summer following the spring crop harvest, when the plant evapotranspiration will have dried the soil.
- 1.5.9 Once the placement of soils into each stockpile has been completed, rainfall and soil moisture conditions are of lesser importance, providing they do not lead to significant environmental impacts, such as erosion and discharges of sediment laden water from the stockpiles to drainage ditches and other watercourses.

1.6 Preparation

- 1.6.1 Mark and signpost the undisturbed areas where no construction activities or vehicle trafficking over/driving on is to take place per detailed works plans and construction method statements (to be prepared post-consent by the Contractor). Any trees, hedgerows or valuable habitats which are to be retained should be marked out with barrier tape; and subsequently protected and managed.
- 1.6.2 As per the requirements of detailed works plans and construction method statements (to be prepared post-consent by the Contractor), any underground services crossing the area of soil stripping area are to be surveyed and their depth and position clearly marked to ensure they are not impacted by the stripping works. After stripping, to ensure the integrity of the service infrastructure is maintained, the service location may require fencing off; or if the area over the service is to be trafficked additional protection or mitigation may be required.



- 1.6.3 Mark soil storage areas for different types of topsoil, subsoil and mineral substrate. In some locations, the excavated soil profile may contain more than one distinct subsoil horizon (layer). Where this occurs, due to the different properties of the different horizons, they must be excavated and stored separately.
- 1.6.4 At designated crossings (specified in the location-specific construction method statements) a 2 m width of topsoil will be left unstripped at either side of the ditch/watercourse to act as a filter for water run-off.
- 1.6.5 To reduce the likelihood of anaerobic conditions developing within the topsoil stockpile prior to the soil strip commencing the topsoil surface should either be bare, under stubble, or have only short surface vegetation. To achieve short surface vegetation (for example in areas of permanent pasture or under a hay crop), if not already done so prior to the land being handed over to the Project, the area should be mown or strimmed. Cuttings must not be added to or mixed with the stripped soil, as the presence of excessive amounts of plant material in the stockpile will be detrimental to its quality due to its putrefaction (rotting) in anaerobic conditions. Alternatively, the vegetation may be killed off by application of a suitable, Environment Agency approved, non-residual herbicide applied not less than two weeks prior to commencement of soil stripping operations at the location. Herbicide may only be used with the consent of the landowner and subject to the conditions/restrictions within the contract.
- 1.6.6 The site staff must be competent to perform the tasks as they have the potential to cause an environmental impact. The training and awareness is to be ensured according to the procedures and tools described in the Construction Environmental Management Plan (CEMP). Carry out toolbox talks with all personnel involved in the groundworks communicating the principles of good practice in soil management and its goals.

1.7 Soil stripping

- 1.7.1 Topsoil can be stored on either topsoil (of the same type) or on subsoil. Subsoil can ONLY be stored on subsoil and therefore the topsoil must be stripped from subsoil storage areas in advance of subsoil stripping.
- 1.7.2 The stripping method should follow one of the suggested methods as described in the MAFF's Good Practice Guide to Handling Soils (Ref: 1-2). When preparing the trenches for installing the proposed cables and during the preparation of the working areas, the excavated sub soil will be stored on the opposite margin of the working area to the top soil. In areas where there is a clear subsoil and topsoil distinction, the topsoil should be placed on one side of the trench, and the subsoil on the other. Then once the cable has been laid the subsoil can be added back first, then the topsoil second, to reinstate the soil structure to its original order and state.

1.7.3 Where soils are to be stored away from the excavation area, two excavators and one transport vehicle will be required for soil stripping operations. One excavator will be required to undertake the soil stripping and the other to form the soil stockpiles. The excavator undertaking the soil stripping should be fitted with a toothed bucket, except in the areas of known archaeological significance or high archaeological potential (see above), where a toothless bucket should be employed to prevent damage to the underlying archaeology. The method, if correctly carried out, should avoid severe compaction as soil trafficking is minimised. The concept of this method is shown in Plate 1 and Plate 2. It is not foreseen on this project that it will be necessary to store topsoil or subsoil away from the immediate area where it has been excavated.

1.7.4 The size of the earthmoving plant to be used should be tailored to the size of the area to be stripped and the space available within the working area. The use of a long reach excavator, which will minimise the need for movement across the soil surface, and the use of tracked vehicles or vehicles with a low ground bearing pressure is recommended to further reduce soil compaction.

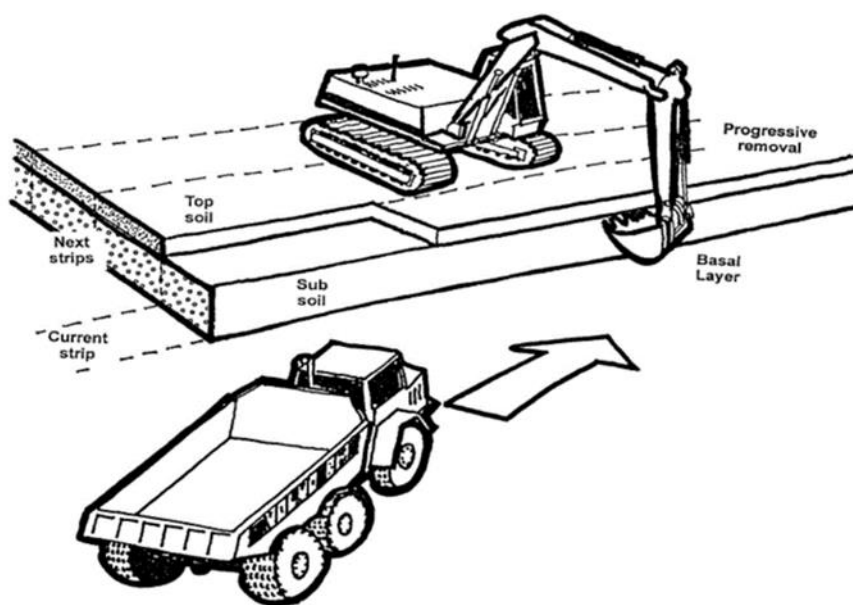

*Plate 1: Stripping with excavators and dump trucks: removal of topsoil from a strip.
Reproduced from MAFF, 2000 (Ref: 1-2)*

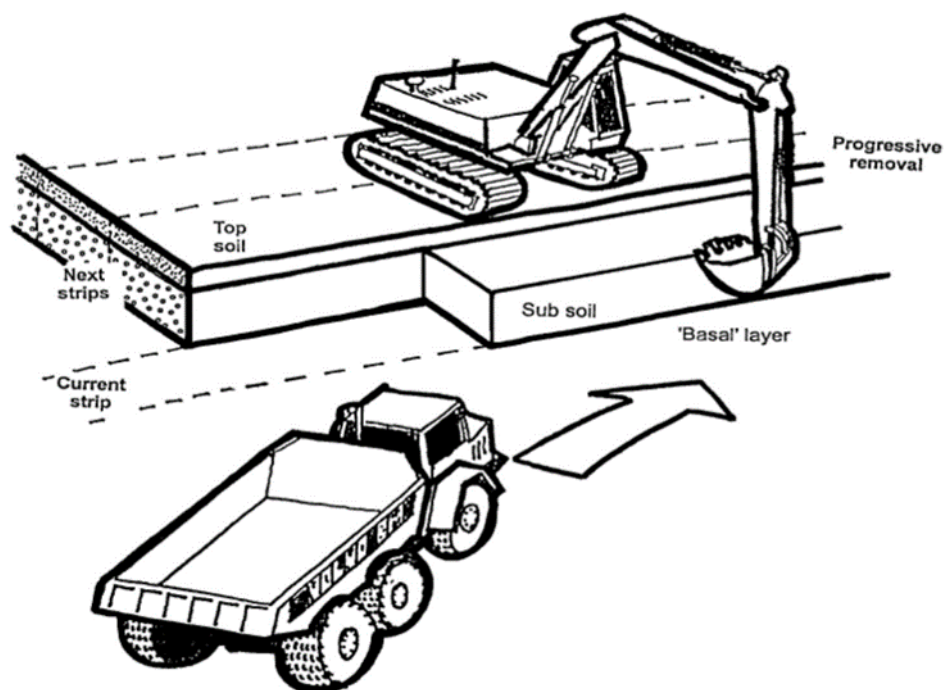

Plate 2: Stripping with excavators and dump trucks: removal of subsoil from a strip.
Reproduced from MAFF, 2000 (Ref: 1-2)

- 1.7.5 Prior to commencement of soil stripping, the width of each strip must be determined. Strip width is determined by the length of the excavator boom less the stand-off to operate; typically, 3 to 4 m.
- 1.7.6 The strip width should make full use of the reach of the excavator. This will maximise the time the excavator can remain at a fixed location, before moving further along the strip; minimising the number of locations subject to the weight of standing plant.
- 1.7.7 The depth of the topsoil strip is to be determined on a 'location by location' basis. During the strip, the excavator should stand on the surface of the topsoil, digging the topsoil to the required depth and forming the stockpile or loading it into the transport vehicle (dump truck). Following topsoil removal, the subsoil can be excavated (if required). Topsoil should be recovered to the full width of the strip without contamination with the subsoil. The boundary between the topsoil and subsoil is usually very clearly visible through a change in colour (the topsoil being much darker due to greater organic matter content). However, this may not always be the case, as often the topsoil gradually transitions into subsoil, and their colours are similar. Therefore, the depth of the topsoil to be stripped must be determined by measuring the depth from the surface (excluding any vegetation) using the soil survey data as described above.
- 1.7.8 The key points to minimise soil compaction and maximise its readiness for reuse are:



- The operations of the vehicles (excavators and dumper trucks, if relevant) on the topsoil should be minimised.
- Plant and machinery are to only work when ground conditions enable their maximum efficiency.
- Soils should only be handled when dry
- Stop conditions as set out in section 3.5 must be observed.
- Protect the subsoil from ponding of water by diverting water inflow away from it.
- Do not work when there is standing water on the topsoil or subsoil surface.

1.8 Creation of soil stockpiles

- 1.8.1 Correct storage/stockpiling will maintain soil quality and minimise damage to soil structure and soil biota. This ensures that the soil will readily recover once re-spread, promoting timely and effective restoration. Stockpiled soil must not be vulnerable to compaction or erosion; must not cause pollution to surrounding watercourses; and must not increase flood risk to the surrounding area.
- 1.8.2 Potential soil erosion and water pollution can be minimised through a number of good practice measures, including, but not limited to; the avoidance of trafficking over/driving on the soil stockpiles, the seeding of stockpiles; and the use of intermittent spaces in the stockpiles.
- 1.8.3 Soil should not be stacked closer than 5 m from a watercourse or ditch. Gaps shall be left where necessary to allow for surface water drainage and avoid the catchment (ponding) of water behind stockpiles.
- 1.8.4 Ecologically important soils, for example woodland or hedgerow soils, must be stripped and stored separately to ensure the seedbank is retained and not mixed with neighbouring agricultural soils. These stockpiles must be appropriately marked out and clearly signed to ensure that they are easily identifiable at restoration, as specified in the location-specific construction method statements.
- 1.8.5 Generally, topsoil stockpiles should not exceed 3 m in height and subsoil stockpiles should not exceed 5 m in height. However, if the soil to be stockpiled is dry (below the plastic limit) formation of higher stockpiles may be permissible, if required, as the soil is likely to remain dry in the core of the stockpile for the entire storage period. However, the appropriateness of higher stockpiles will need to be established on a location by location basis.
- 1.8.6 Stockpiles are to be formed by 'loose-tipping' followed by 'shaping' to form a level surface on top of the pile and uniform gradients down the sides. During 'forming', the top and sides should be smoothed so that they can shed water, ensuring that the entry of the water to the stockpile is limited and that the stored soil remains dry; and helping prevent erosion and ponding. This is achieved by dragging the bottom of the excavator bucket along the stockpile surface.



- 1.8.7 The natural angle of repose of a soil, and hence the maximum gradient (slope) of the stockpile sides, depends upon its texture and moisture content. The maximum achievable slope angle is 40° however, shallower angles are often more appropriate.
- 1.8.8 The topsoil and subsoil stockpiles along cable trenches are to be formed using one back-acting/360° excavator as they will be too close to the excavation to require transport in a separate vehicle.

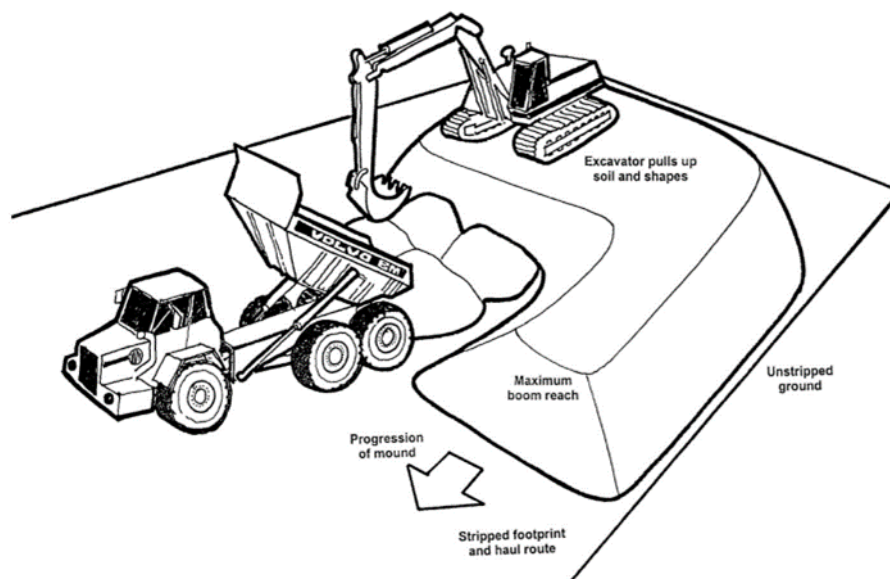

Plate 3: Soil storage mound construction with excavators and dump trucks. Reproduced from MAFF, 2000 (Ref: 1-2)

- 1.8.9 If transport is required, follow the method described in the MAFF Guide, Sheet 2: Building Soil Storage Mounds with Excavators and Dump Trucks illustrated in Plate 3 (Ref: 1-2). A dump truck should transfer soil material between the stripping and storage areas. The dump truck should enter the storage area, reverse and back-tip the soil load starting at the furthest end of the stockpile (see Plate 3). Repeat the process of tipping the soil against the forming stockpile and without the wheels traversing onto previously tipped material. For this operation, a second back-acting/360° excavator will be required with the boom reach allowing it to form a stock pile of up to 4 m while standing on it.
- 1.8.10 Use of a front-loading machine to form the stockpile is possible if this is a Contractor's preference. If this alternative is chosen; the tipped soil must not be travelled or pushed with a bulldozer blade. It must be lifted by the front-loading machine and tipped into place to form a desired stockpile height. The top and side surfaces of the stockpile must be formed in order to shed the rainwater.



1.9 Stockpile Maintenance

- 1.9.1 In cases where is expected that the soil will be stored for a period of more than six months, the stockpiles should be seeded with appropriate low maintenance grass/clover mixture (for example EG22c Emorsgate Seed, or similar: to be agreed with landowner and subject to the conditions/restrictions within the contract; to protect the soil against erosion, minimise soil nutrient loss, and maintain soil biological activity. Appropriate seeding will also help prevent colonisation of the stockpile by nuisance weeds that could spread seed onto adjacent land.
- 1.9.2 In the period where vegetative cover on the stockpiles is establishing, where required during dry weather, the stockpiles will be sprayed with water to prevent wind erosion (generation of dust) and to ensure that the seeds establish.
- 1.9.3 The stockpile vegetation cover is to be managed (by spraying, mowing or stripping as appropriate and as defined in location-specific construction method statements, or similar), to prevent the spread of seeds from the stockpile onto adjacent land.
- 1.9.4 The condition of the stockpiles is to be regularly monitored. If rainwater gathers on the stockpile surface or in areas directly adjacent to them, drainage pathways to soakaway area away from the stockpile should be provided.

1.9.5 Stockpile Records

- 1.9.6 The locations and footprints of each stockpile should be accurately recorded on a plan of appropriate scale. Marker post should be provided in locations which have been surveyed and recorded.
- 1.9.7 The approximate volume of each stockpile should be recorded, along with details of the type of soil stored.

1.9.8 Drainage

- 1.9.9 Prior to soil stripping, where required, pre-construction drainage will be installed per specification provided by a specialist drainage contractor. This drainage is designed to prevent water entering the working area.
- 1.9.10 Gaps shall be left between soil stockpiles where necessary to allow for surface water drainage and avoid the catchment (ponding) of water behind stockpiles. In certain areas (as defined in location-specific construction method statements or similar) 'grips' may be dug across the working area at predetermined locations to prevent erosion and prevent ponding against stockpiles. Appropriate measures such as stones silt traps and silt fencing will be employed as required.



Appendix 2 Work Plans

To be added to the final CEMP prior to the close of the Examination

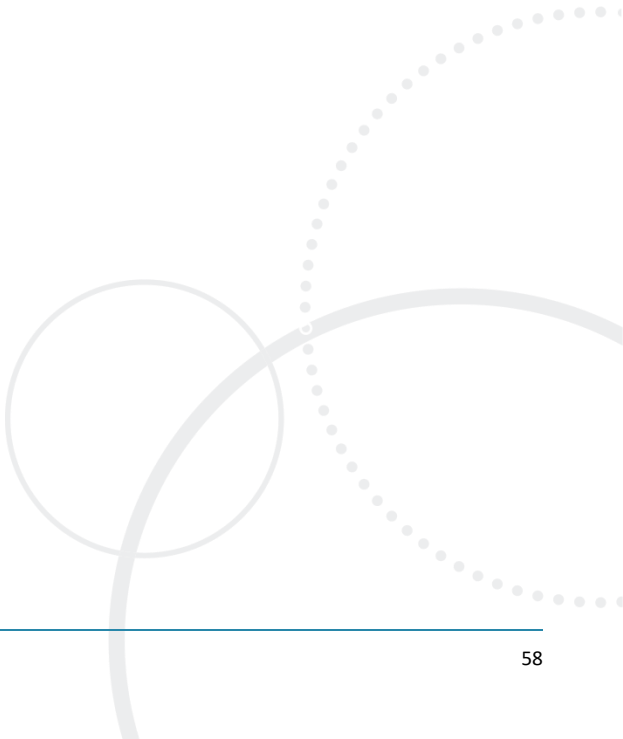



Appendix 3 Flood Risk Assessment and Drainage Strategy

To be added to the final CEMP prior to the close of the Examination



ITPenergised is a leading international consultancy delivering expert energy, environmental, engineering, technical advisory and asset management services; facilitating the transition to net zero.

Visit the ITPenergised group offices in:

Bristol, London, Edinburgh, Glasgow, Buenos Aires, Madrid, Delhi, Beijing, Canberra, Auckland

Sectors:

Onshore Renewables & Storage | Offshore Wind & Marine Renewables | Oil & Gas Transition
Property & Urban Regeneration | Corporate, Industrial & Manufacturing

